

Simpson

INSTRUMENTS THAT STAY ACCURATE

OPERATOR'S MANUAL

MODEL 480
GENESCOPE
FOR
FM-TV

A. M. MARKER GENERATOR
CRYSTAL CALIBRATOR
FM GENERATOR
OSCILLOSCOPE

SIMPSON ELECTRIC COMPANY

5200 W. Kinzie St., Chicago 44, Illinois, COl 1-1221

In Canada, Bach-Simpson, Ltd., London, Ontario

Simpson

INSTRUMENTS THAT STAY ACCURATE

OPERATOR'S MANUAL

MODEL 480
GENESCOPE
FOR
FM-TV

A. M. MARKER GENERATOR
CRYSTAL CALIBRATOR
FM GENERATOR
OSCILLOSCOPE

SIMPSON ELECTRIC COMPANY

5200 West Kinzie St., Chicago 44, Illinois. COlumbus 1-1221

In Canada, Bach-Simpson, Ltd., London, Ontario

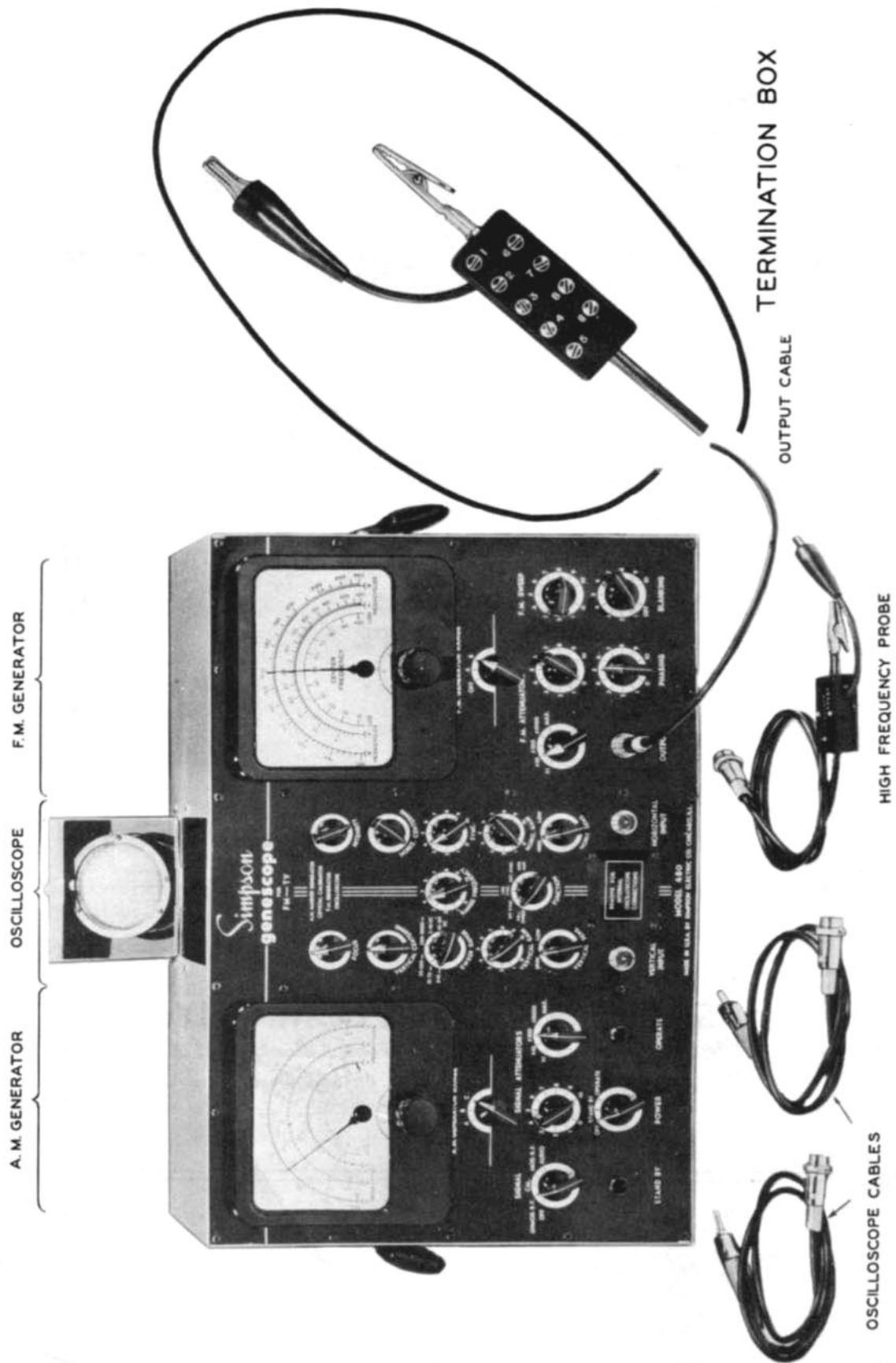

FIG. 1. THE MODEL 480 GENESCOPE

MODEL 480 GENESCOPE

The Simpson Model 480 **GENESCOPE** has been designed carefully to supply all the necessary signal sources for the proper alignment and servicing of FM and TV receivers. In addition to signal sources, the **GENESCOPE** includes a high sensitivity oscilloscope of advance design complete in every detail. It is equipped with a high frequency crystal probe for signal tracing.

There are two separate tunable oscillator sections. Each oscillator section is provided with a large precision vernier dial having a 20:1 knob-to-pointer ratio and a 1000 division logging scale. They are easy to read and easy to set to any exact frequency within the range of the generator. Each oscillator section has a separate output attenuator. With these the operator can achieve the desired balance of signal strengths for mixed outputs.

Everything possible has been done to make the **GENESCOPE** the most accurate, flexible and convenient instrument available. Each part of this instrument has been considered carefully for long life and stability. Many of the most vital components are manufactured under rigid supervision within our own plants in order to insure lasting accuracy and many years of uninterrupted service.

DESCRIPTION

The **GENESCOPE** is arranged in three major sections. See figure 1.

The left-hand section contains a crystal calibrator, a 400 cycle audio oscillator, and a three range r-f generator which can be amplitude modulated with the output of the 400 cycle audio oscillator.

The desired type of signal is selected by the **SIGNAL** switch (left). The **SIGNAL** switch has five positions, named **OFF**, **UNMOD. R.F.**, **CAL.**, **MOD. R.F.**, and **AUDIO**. When the switch is in the **OFF** position, the entire A. M. Generator section is inoperative. When the switch is in the **UNMOD. R.F.** position, an unmodulated r-f signal is available through the **OUTPUT** jack and cable. The amplitude is controlled with the **SIGNAL ATTENUATORS**, with both fine and coarse adjustments (center and right). When the switch is in the **CAL.** position, the output of a 5.0 mc. crystal oscillator is mixed with the r-f signal to produce a "beat" according to the information in table 1. The beat patterns can be observed on the oscilloscope. By using table 1 and the oscilloscope, any frequency within the range of the instrument can be produced quickly and precisely. When the switch is in the **MOD. R.F.** position, the r-f signal is amplitude modulated 30% with a 400 cycle audio frequency and the modulated signal is available through the **OUTPUT** jack and cable. The amplitude is controlled by the **SIGNAL ATTENUATORS**. When the switch is in the **AUDIO** position, a 400 cycle signal is available through the **OUTPUT** jack and cable. The amplitude is controlled by the **SIGNAL ATTENUATORS**.

A potentiometer and a five-position switch together comprise the **SIGNAL ATTENUATORS**. The switch, at the right, is the coarse amplitude selector for the output of the a-m generator, and the potentiometer acts as a fine adjustment on amplitude.

The **A. M. GENERATOR RANGE** switch, located just below the center of the dial, selects each of three bands of radio frequencies. The tuning knob varies the frequency throughout each band.

Band A. Fundamental 3.3 to 7.8 mc.	Second harmonic 6.6 to 15.6 mc.
Band B. Fundamental 15 to 38 mc.	Second harmonic 30 to 76 mc.
Band C. Fundamental 75 to 125 mc.	Second harmonic 150 to 250 mc.

The POWER switch (lower center) controls the power input to all three sections of the GENESCOPE . When the switch is in the OFF position the entire instrument is turned off. In the STAND BY position, all the tube filaments are turned on but no plate voltage is applied. In the OPERATE position, plate voltages are applied. The green light is on for both STAND BY and OPERATE positions of the switch, and the red light is on for the OPERATE position only.

The center section of the GENESCOPE contains the oscilloscope and its associated controls. The 3" cathode ray tube of the oscilloscope is mounted vertically in the case in order to conserve bench space. The pattern on the face of the cathode ray tube is viewed with a mirror in an adjustable hinged section of the top of the cabinet. The angle at which the mirror is set may be adjusted quickly for any position of the operator. The tube face is placed well below the top surface of the cabinet to shield it from incident light without hampering the operator's view with narrow angle light shields; this produces an image which is always clear and bright.

Each oscilloscope control is labelled and has a purpose as follows:

FOCUS	Adjusts sharpness of trace.
INTENSITY	Adjusts brightness of trace.
VERTICAL CENTERING	Moves trace up or down.
HORIZ. CENTERING	Moves trace to right or left.
SWEEP RANGE	Coarsely selects linear sweep frequencies.
RANGE FREQUENCY	Fine adjustment to frequencies in band selected with SWEEP RANGE switch.
SYNC.	Controls amplitude of synchronizing voltage which may be used to assist in locking a pattern in position horizontally when using a linear sweep.
VERTICAL GAIN	Fine adjustment to control portion of input signal fed to the vertical amplifier and resulting pattern height.
VERTICAL SENS.	Coarse control on portion of horizontal signal fed to the horizontal vertical amplifier.
HORIZ. CENTERING	Moves trace to right or left.
HORIZ. GAIN	Fine adjustment to control portion of horizontal signal fed to the horizontal amplifier and resulting pattern width.
HORIZ. SENS.	Coarse control on portion of input signal fed to the horizontal amplifier.
FUNCTION	Selects the source of horizontal deflection signal and of synchronizing signal.

The FUNCTION switch has five positions labelled for the type of signal fed through the horizontal amplifier to the horizontal deflection circuit of the cathode ray tube. In the 60 \sim SWEEP position a 60 cycle sine wave voltage is applied to the horizontal deflection circuits through the amplifier; this sine wave sweep is especially useful for visual alignment of f-m circuits. In the INT. SYNC., LINE SYNC. and EXT. SYNC. positions the linear sweep circuit of the oscilloscope furnishes the horizontal amplifier input signal. The sweep circuit can be synchronised by a signal from the source named in the switch position; from the vertical input for INT. SYNC., from the 60 cycle power line for LINE SYNC., or from a signal connected between the external sync. screw on the internal connections board and ground for the EXT. SYNC. position. In the HOR. AMP. position, any signal fed into the HORIZONTAL INPUT jack is connected to the horizontal amplifier input. The linear sweep circuit does not function with the switch in the 60 \sim SWEEP position or the HOR. AMP. position.

The jack labelled VERTICAL INPUT is the connection point on the front panel through which an a-c signal is sent to the vertical amplifier.

Under the cover plate labelled REMOVE FOR INTERNAL OSCILLOSCOPE CONNECTIONS are 15 screws which allow many variations of oscilloscope connections.

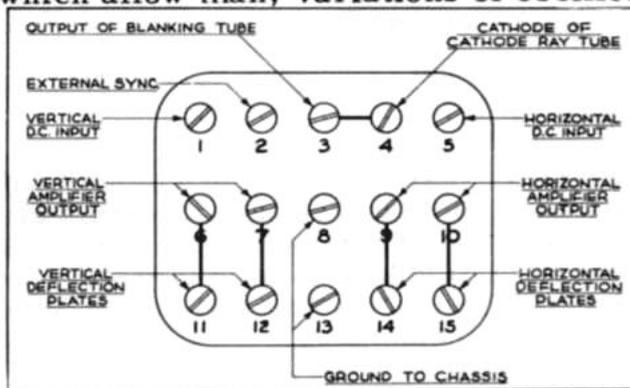

FIG. 2. INTERNAL OSCILLOSCOPE CONNECTIONS

The screw terminals are numbered from 1 to 15 and are connected as follows:

- Terminal 1. Vertical amplifier d-c input. Used as an alternate to VERTICAL INPUT jack for a d-c input to the vertical amplifier.
- Terminal 2. External sync. Used to connect a signal through the FUNCTION switch in its EXT. SYNC. position to synchronize the linear sweep before applying it to the horizontal amplifier.
- Terminal 3. Output of blanking tube. A source of signal normally used to blank the return trace of the linear sweeps when connected to terminal 4.
- Terminal 4. Cathode of cathode ray tube through a coupling capacitor. Normally jumpered to terminal 3. When jumper is removed, an intensity modulation may be superimposed on the pattern on the face of the cathode ray tube by connecting the signal to terminal 4.
- Terminal 5. Horizontal amplifier d-c input. Used as an alternate to HORIZONTAL INPUT jack for a d-c input to the horizontal amplifier when the FUNCTION switch is in the HOR. AMP. position.
- Terminals 6 & 7. Vertical amplifier output. Normally terminal 6 is connected to terminal 11 and terminal 7 to terminal 12 to connect the amplifier output to the vertical deflection plates.
- Terminal 8. Ground to chassis. Convenient ground contact for any input signal.
- Terminals 9 & 10. Horizontal amplifier output. Normally terminal 9 is connected to terminal 14 and terminal 10 to terminal 15 to connect the amplifier output to the horizontal deflection plates.
- Terminals 11 & 12. Vertical deflection plates of cathode ray tube. Normally terminal 11 is connected to terminal 6 and terminal 12 to terminal 7. When the jumpers are removed, a signal may be injected directly between terminals 11 and 12 to cause a vertical deflection on the cathode ray tube without the aid of the vertical amplifier.

NOTE: Terminals 11 and 12 have a d-c voltage of about 175 volts with respect to the chassis. Use a coupling capacitor in series with each side of an input fed to these terminals.

Terminal 13. Ground to chassis. Convenient ground contact for any input signal.

Terminals 14 & 15. Horizontal deflection plates of cathode ray tube. Normally terminal 14 is connected to terminal 9 and terminal 15 to terminal 10. When the jumpers are removed, a signal may be injected directly between terminals 14 and 15 to cause a horizontal deflection on the cathode ray tube without the aid of the horizontal amplifier.

NOTE: Terminals 14 and 15 have a d-c voltage of about 175 volts with respect to the chassis. Use a coupling capacitor in series with each side of an input fed to these terminals.

The jack labelled HORIZONTAL INPUT is the connection point on the front panel through which an a-c signal may be fed to the horizontal amplifier. The FUNCTION switch must be in the HOR. AMP. position to complete this input connection.

The right hand section of the GENESCOPE contains a frequency modulated signal generator, a 140 mc. fixed frequency oscillator, a mixer, and phasing and blanking circuits. The output of the f-m signal generator is connected through an attenuator to the OUTPUT jack. The OUTPUT jack serves both the a-m and the f-m signal generators.

The F.M. GENERATOR RANGE switch below the center of the dial has three positions. In the OFF position, the f-m generator section of the GENESCOPE is inoperative. In the A position, both the 140 mc. fixed frequency oscillator and the tunable f-m oscillator are operating; the output frequency from the mixer is the difference of these two frequencies and is in the range of 2 to 120 mc. In the B position, the 140 mc. fixed frequency oscillator is turned off, and the f-m oscillator fundamental frequency is available at the output; the tunable range of this band is 140 to 260 mc. The tuning knob in the dial serves to select any frequency within the range indicated on the CENTER FREQUENCY dial.

The F.M. ATTENUATORS are two controls which act as coarse and fine adjustments. A 5-position switch provides coarse control on attenuation, and a continuously variable potentiometer provides the fine control.

The F.M. SWEEP control (right side) regulates the amount of frequency variation due to modulation. The center frequency can be swept through a bandwidth of zero to 15 megacycles. The rate at which it is swept through the selected range and back is the modulation frequency of 60 cycles.

The PHASING control is a phase adjuster on the 60 cycle sine wave signal furnished to the horizontal amplifier when the FUNCTION switch is in the 60~ SWEEP position. It is to be used to sweep the trace on the oscilloscope in phase with the 60 cycle sweep modulation on the carrier. This will superimpose the response pattern on the forward trace over the pattern on the return trace.

The BLANKING control has a potentiometer and a switch on the same shaft. The switch is actuated at the full counter-clockwise knob position. When the knob is in the OFF position, no blanking occurs and the F.M. Generator oscillates continuously. When the knob is rotated toward its numbered range, the switch actuates and applies a 60 cycle voltage to the f-m oscillator grid to block out oscillations during its negative half cycles.

Turning the BLANKING control through its numbered range changes the phasing of the blocking voltage with respect to the horizontal sweep to the oscilloscope. Thus either the forward or the return trace can coincide with the period of oscillation and the alternate trace can coincide with the time during which the oscillator is turned off. On the oscilloscope, the operator will see a single response curve with a base line through it.

Four cables are supplied for making connections between the GENESCOPE and a receiver. The output cable which connects the GENESCOPE OUTPUT jack to the input of the receiver includes a variable termination network which can be adapted quickly to the receiver input impedance. See figure 19 and table 2 for further information. The cable with the high frequency probe is used for the VERTICAL INPUT to the oscilloscope when amplitude modulated high frequencies are involved. The other two cables are used for ordinary connections to the HORIZONTAL and VERTICAL INPUT jacks of the oscilloscope.

During normal alignment procedure, the signal is sent out of the OUTPUT jack to the receiver under test, returned to the GENESCOPE through the VERTICAL INPUT jack, through the FUNCTION switch in the 60 \sim sweep position, through the SIGNAL switch in any position except CAL., and to the vertical amplifier. This arrangement was designed to simplify the alignment operation by internal switching of the oscilloscope vertical input. When the SIGNAL switch is in CAL. position, the signal fed to the vertical amplifier is the audio beat frequency produced by the crystal calibrator and the a-m generator near any of the calibration points listed in table 1.

CALIBRATION PROCEDURE FOR DETERMINING TUNABLE FREQUENCIES WITH CRYSTAL ACCURACY

The GENESCOPE has two precision vernier dials; one is used for the A-M Generator and the other for the F-M Generator. The A-M Generator can be used as a marker generator for both FM and TV alignment. It needs to be extremely accurate to adjust FM and TV receivers properly. The basic accuracy is better than 1% (output frequency against dial indications), but it needs to be even more accurate for alignment. For this reason, the GENESCOPE is provided with a crystal oscillator standard having an accuracy of .05% or better. It is by use of this standard and the logging scale of the A-M Generator that frequencies may be established with crystal accuracy at any point in the range of the A-M Generator.

To prepare the GENESCOPE for calibration, turn the POWER switch to OPERATE; SIGNAL switch to CAL.; SIGNAL ATTENUATORS to a low setting*; A.M. GENERATOR RANGE switch to A, B, or C, depending on the frequency to be established; oscilloscope FUNCTION switch to 60 \sim SWEEP; VERT. SENS. to HIGH; VERTICAL GAIN between 6 and 10; and INTENSITY, FOCUS, VERTICAL CENTERING, and HORIZ. CENTERING for a clear, bright, centered line. Adjust the width of the line to about two inches with the HORIZ. GAIN control. Slowly rotate the A-M Generator tuning knob while observing the oscilloscope screen. At various tuning points a pattern will appear on the tube. Rotate the dial slowly through the area in which a pattern can be seen. First a high frequency appears, then as the knob is rotated slowly, note that the frequency reduces to zero and then increases to a high frequency again and disappears. The patterns are the results of beat frequencies developed between the a-m oscillator and the 5.0 mc. crystal oscillator.

The point at which the pattern reduces to zero frequency is known as zero beat and is the point at which the two oscillators are in step. The zero beat point is identified easily by the fact that the slightest movement of the dial in either direction will cause the pattern to increase in height and frequency. At zero beat the pattern is, essentially, a straight line. At the higher frequencies it is sometimes difficult to bring the pattern

* FOR CALIBRATING, THE SIGNAL ATTENUATORS DO NOT ADJUST THE AMPLITUDE, BUT THE POTENTIOMETER NEEDS TO BE SET BELOW 8 TO OBTAIN BETTER BEAT PATTERNS.

down to exact zero beat, but this is not important so long as it is brought down to within two or three hundred cycles.

Note that some points on the dial will produce much larger patterns than others. This is due to the order of harmonics of the two oscillators producing the beat pattern. The lower harmonics result in a stronger beat pattern. Some of the weaker patterns may require a higher setting of the VERTICAL GAIN control while some of the stronger may require a lower setting.

BAND A				BAND B				BAND C			
FUNDAMENTAL MEGACYCLES	2ND HARMONIC MEGACYCLES	VAR. OSC. HARM.	XTL. OSC. HARM.	FUNDAMENTAL MEGACYCLES	2ND HARMONIC MEGACYCLES	VAR. OSC. HARM.	XTL. OSC. HARM.	FUNDAMENTAL MEGACYCLES	2ND HARMONIC MEGACYCLES	VAR. OSC. HARM.	XTL. OSC. HARM.
*3.33	*6.67	3	2	*15.00	*30.00	1	3	*70.0	*140	1	14
3.46	6.92	13	9	15.83	31.66	6	19	72.5	145	2	29
3.50	7.00	10	7	16.00	32.00	5	16	*75.0	*150	1	15
3.57	7.14	7	5	16.25	32.50	4	13	77.5	155	2	31
3.64	7.28	11	8	*16.67	*33.34	3	10	*80.0	*160	1	16
*3.75	*7.50	4	3	17.00	34.00	5	17	82.5	165	2	33
3.89	7.78	9	7	*17.50	*35.00	2	7	*85.0	*170	1	17
*4.00	*8.00	5	4	18.00	36.00	5	18	87.5	175	2	35
4.09	8.18	11	9	*18.33	*36.66	3	11	*90.0	*180	1	18
*4.17	*8.34	6	5	18.75	37.50	4	15	92.5	185	2	37
4.29	8.58	7	6	19.00	38.00	5	19	*95.0	*190	1	19
4.38	8.76	8	7	*20.00	*40.00	1	4	97.5	195	2	39
*4.44	*8.88	9	8	21.00	42.00	5	21	*100.0	*200	1	20
4.50	9.00	10	9	21.25	42.50	4	17	102.5	205	2	41
4.55	9.10	11	10	*21.67	*43.34	3	13	*105.0	*210	1	21
4.58	9.17	12	11	22.00	44.00	5	22	107.5	215	2	43
*5.00	*10.00	1	1	*22.50	*45.00	2	9	*110.0	*220	1	22
5.63	11.26	8	9	23.00	46.00	5	23	112.5	225	2	45
*5.71	*11.42	7	8	*23.33	*46.66	3	14	*115.0	*230	1	23
5.83	11.66	6	7	23.75	47.50	4	19	117.5	235	2	47
6.00	12.00	5	6	24.00	48.00	5	24	*120.0	*240	1	24
*6.25	*12.50	4	5	*25.00	*50.00	1	5	122.5	245	2	49
6.43	12.86	7	9	26.25	52.50	4	21	*125.0	*250	1	25
*6.67	*13.34	3	4	26.67	53.34	3	16				
6.87	13.74	8	11	*27.50	*55.00	2	11				
*7.00	*14.00	5	7	28.33	56.66	3	17				
7.14	14.28	7	10	28.75	57.50	4	23				
7.22	14.44	9	13	*30.00	*60.00	1	6				
*7.50	*15.00	2	3	31.67	63.34	3	19				
7.72	15.44	11	17	*32.50	*65.00	2	13				
7.78	15.56	9	14	33.33	66.66	3	20				
*8.00	*16.00	5	8	*35.00	*70.00	1	7				
				36.67	73.34	3	22				
				*37.50	*75.00	2	15				

ASTERISK (*) INDICATES THE STRONGER CALIBRATION POINTS.

TABLE I. CRYSTAL CALIBRATING POINTS

Table I has been developed to assist the operator in identifying the frequencies where beat patterns occur and the oscillator harmonics which produce them. The frequencies

preceded by an asterisk (*) will produce the stronger patterns and should be used wherever possible.

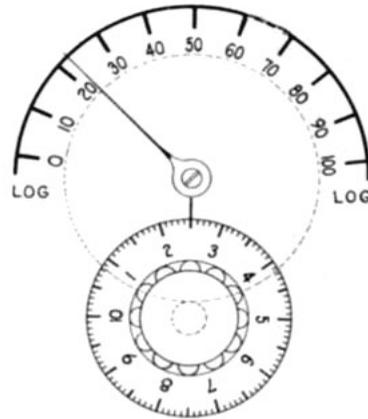

FIG. 3. GENESCOPE LOGGING DIAL

Figure 3 is an illustration of the logging arcs as they are used in both A-M and F-M Generator dials. The upper arc of each dial is divided into 10 equal divisions marked from 0 to 100. On the knob shaft is another dial marked in 100 equal divisions. The gear ratio between the knob shaft and the pointer is such that one revolution of the knob shaft moves the pointer through one of its ten divisions. Thus each division of the logging scale is effectively divided into 100 parts and the entire arc into 1000 parts. The minor divisions may be divided visually for further increasing the number of logging points and the resulting accuracy of calibration information. For example, the reading on the logging scale in figure 2 is 22.5. The main pointer shows that the setting is 20 plus some additional amount, and the dial on the knob shaft shows that the additional amount is 2.5. If the knob were turned slightly counterclockwise so the dial setting were half way between 2.5 and 2.6, it could be read as 2.55 and the indicated setting would be 22.55 divisions. Take advantage of the visual division of these marked points and effectively increase the accuracy to 2000 or more scale divisions.

DETERMINING AN EXACT FREQUENCY

There are two methods by which a given frequency setting may be obtained. They are somewhat similar but one is simpler, while the other yields more accurate results.

The first method is the simpler and, with practice can produce acceptable results for most purposes. The process consists of first determining the number of logging scale divisions which correspond to a one megacycle frequency difference which includes the desired frequency; second, mathematically figuring the number of logging scale divisions the desired frequency is away from a crystal check point (see table 1); third, tuning to the crystal check point and observing its logging scale reading; and fourth, adding or subtracting the determined number of scale divisions to or from the reading at the crystal check point. When the logging scale is set to the reading obtained in the fourth step, the desired frequency should be tuned by the oscillator.

A step-by-step example of the first method follows:

Assume that a frequency of 20.75 mc. is desired in the A.M. Generator. Note that table 1 shows a strong calibration check point at 20 mc. Set the A.M. GENERATOR RANGE switch to B, the SIGNAL switch to CAL., and the SIGNAL ATTENUATORS and VERTICAL GAIN as required to see the zero beat indications on the oscilloscope. Have the POWER switch in either STAND BY or OPERATE position for at least 15 minutes before beginning the calibration to allow the GENESCOPE to warm up, and set it in the OPERATE position to calibrate.

1. Observe the tuning arc of range B from a position directly in front of the pointer (to avoid parallax error) and set the pointer over the 20 megacycle mark on the dial. Record the logging scale reading for this setting. On a sample unit the setting was 36.0 (use your readings, since there will be variation from one unit to another which does not affect the accuracy in any way.) Set the pointer exactly over the 21 megacycle mark on the dial. Again record the logging scale reading. The sample unit read 40.45 for this setting. Subtract the first reading from the second to obtain the number of scale divisions which correspond to one megacycle. $40.45 - 36.0$ is 4.45 divisions.

2. Determine the frequency difference, in megacycles, between the desired frequency and a check point (table 1); then multiply this difference by the result of step 1 above. In the example, the desired frequency of 20.75 mc. is .75 mc. away from the strong calibration check point at 20 mc. The result of step 1 shows that in this area of the sample unit, a change of 4.45 scale divisions corresponds to a change of one megacycle. Multiply $.75 \times 4.45$ to get 3.33 divisions.

3. With the aid of the oscilloscope, tune the generator to its zero beat position for the chosen calibration check point and record the logging scale setting for this position. In the example, the sample unit was tuned to 20 megacycles and the logging scale read 36.2 divisions.

4. Add or subtract the results of steps 2 and 3. Add if the check point frequency is lower than the desired frequency, or subtract if the check point frequency is the higher. This sum or difference is the logging scale setting to use for the desired frequency. In the example, add (because the check point is below 20.75 mc.) 3.33 to 36.2 to obtain 39.53 divisions.

Note that the logging scale readings are for a sample unit only. Do not use these readings. Obtain the logging scale readings for your GENESCOPE and use them in a similar way. Although you will be using some frequency settings repeatedly, do not rely on the stability of the instrument over long periods of time; the components are subject to normal deterioration and will cause slight changes of logging scale settings in time.

The second method is different from the first only in the fact that two crystal check point settings are used in place of two dial markings. First, determine the number of logging scale divisions which correspond to the frequency difference between two crystal check points surrounding the desired frequency; second, mathematically figure the number of logging scale divisions the desired frequency is away from one of the check point frequency; third, add or subtract the determined number of scale divisions to or from the reading at the crystal check point. Add if the lower check point is the reference, or subtract if the higher check point is the reference. When the logging scale is set to the reading obtained in the third step, the desired frequency will be tuned by the oscillator. The accuracy obtained by this method is better than .1%.

A step-by-step example of the second method follows. Again, assume that a frequency of 20.75 mc. is desired in the A. M. Generator. Note that the two nearest strong crystal check points are 20.0 and 21.67 mc. (table 1). There are weak check points at 21.0 and 21.25 mc., but these are not recommended because they are close together and difficult to identify. Set the A.M. GENERATOR RANGE switch to B, the SIGNAL switch to CAL., and the SIGNAL ATTENUATORS and VERTICAL GAIN as required to see the zero beat indications on the oscilloscope. Have the POWER switch in either STAND BY or OPERATE position for at least 15 minutes before beginning the calibration to allow the GENESCOPE to warm up, and set it in the OPERATE position to calibrate.

1. With the aid of the oscilloscope, tune the A. M. Generator around the 20 megacycle point for the zero beat indication. Record the logging scale setting for the zero

beat position. On the sample unit, the reading was 36.2 divisions (use the reading on your own GENESCOPE ; this is for an example only). Retune the A. M. Generator around the 21.67 mc. point for the zero beat indication. Record the logging scale setting for this zero beat position. On the sample unit, the reading was 43.3 divisions. Subtract the first reading from the second for the number of logging scale divisions between the check point frequencies. For the example, 43.3 - 36.2 is 7.1 divisions.

2. Determine the frequency difference between the desired frequency and either check point frequency. In the example, the desired frequency (20.75 mc.) is .75 mc. above the lower check point and is .92 mc. below the upper check point. Next find the frequency difference between the two check points. In the example this is 1.67 megacycles. By ratio and proportion, the frequency deviations can be translated into scale divisions for the logging scale;

$$\frac{D_1}{D_2} = \frac{F_1}{F_2} \quad \text{or} \quad D_1 = D_2 \left(\frac{F_1}{F_2} \right)$$

where D_1 = logging scale divisions between one check point and the desired frequency,

D_2 = logging scale divisions between two check points,

F_1 = frequency difference between the same check point (see D_1 above) and the desired frequency,

and F_2 = frequency difference between the two check points.

3. If the lower check point was used to determine D_1 (in step 2), add D_1 to the logging scale setting for this check point; or if the higher check point was used to determine D_1 (in step 2), subtract D_1 from the logging scale setting for this check point. The result will be the logging scale setting for the desired frequency. In the example, add 3.19 to 36.2 to get 39.39 divisions which is a very accurate setting to obtain 20.75 mc. on the sample unit.

Use table 3 at the back of the manual to record the settings for the various frequencies after they have been determined. This will save time whenever the use of any frequency is repeated. Note that four columns apply to each frequency listed: the first column will contain the desired frequency; the second column will have the log scale setting which has been determined for the desired frequency; the third column will have the nearest check point frequency; and the fourth column will have the log scale setting of the crystal check point. To use, after it has once been filled in for any given frequency, zero beat the crystal check point frequency and compare the reading of the logging scale against the listed setting of the fourth column. If the readings are identical, tune to the logging scale setting of the desired frequency listed in the second column and you will have tuned the oscillator to the desired frequency. However, if there is a difference between the log scale setting for zero beat at the check point and the listed setting in the fourth column, it indicates that the components of the oscillator have changed and the logging scale settings need correction. If the log scale setting for the crystal check point has changed up or down one, two, or three divisions, the setting for the desired frequency has changed the same number of divisions in the same direction, so add or subtract the change to or from the column 2 listing to provide a corrected setting. There is enough space in both the second and fourth columns to keep a record of any changes over a

long period of time. For greater accuracy, if the scale settings change more than five divisions, recalculate the column 2 listing rather than add or subtract divisions.

While check points at 20 mc. and 21.67 mc. were used in the example, still greater accuracy of interpolation may be obtained by using the 21 mc. point rather than the 21.67 mc. point. However, this is a weaker check point and is more difficult to identify than a strong check point. Note that the check point at 21 mc. is produced by the 5th harmonic of the generator and the 21st harmonic of the crystal; therefore, this signal will be much weaker than the 21.67 mc. signal created by the 3rd and 13th harmonics, and more vertical gain will be necessary to locate the check point with the oscilloscope.

OSCILLOSCOPE CALIBRATION

In many phases of television service, certain peak-to-peak voltages are specified. The oscilloscope section of the **GENESCOPE** is an excellent device to use for checking these voltages when the oscilloscope input is calibrated to a known value.

The equipment essential for calibration is a variable voltage source and a fairly accurate voltmeter. This may be either AC or DC and may consist of a filament transformer and potentiometer or a battery and potentiometer connected in such a manner that the voltage may be varied from zero to a few volts.

The DC method will probably be more accurate since DC voltmeters are usually more accurate than AC. For DC calibration, remove the plate at the lower center of the panel labelled REMOVE FOR INTERNAL OSCILLOSCOPE CONNECTIONS. Connect wires to terminals 1 and 8 and connect the other ends of the wires across the variable DC voltage supply together with the DC voltmeter. Set the VERTICAL SENS. control to LOW and the VERTICAL GAIN to zero. Adjust the FOCUS and INTENSITY controls for a thin, bright line and adjust the VERTICAL CENTERING control to bring the trace directly under the center cross hatch line. If the trace does not line up with the horizontal line of the cross hatch, rotate the cross hatch over the tube until it does.

A convenient calibration is 1 volt per major screen division; thus each small division represents 0.2 volts, or 10 divisions represent 2 volts. However, any desired calibration may be made. Adjust the voltage supply to 1 volt on the voltmeter then advance the VERTICAL GAIN control. The entire trace will move either up or down depending on the polarity of the supply. Advance the gain control until the trace has moved the required number of divisions and record the gain control setting.

Increasing the voltage to 2 volts on the meter should double the deflection of the trace. The polarity may be reversed in order to check the calibration in the opposite direction. Remove the wires from the terminals. With the gain control in the calibrated position the peak-to-peak voltage of an AC pattern may be determined by simply counting the screen divisions between peaks.

The AC method of calibration requires a variable AC voltage, such as a filament transformer with a potentiometer across the secondary, and an AC voltmeter. Connect the voltmeter and the VERTICAL INPUT cable across the variable arm of the potentiometer. Adjust the FOCUS, INTENSITY, VERTICAL CENTERING, and HORIZONTAL CENTERING controls for a bright, sharp trace which is centered on the tube face. Set the FUNCTION switch to INT. SYNC., SWEEP RANGE to 3-15~, and SYNC. control at 0. Adjust the RANGE FREQUENCY control until 5 or 6 cycles of the AC voltage appear on the tube. A slight advancement of the SYNC. control should lock the pattern in a steady position.

Adjust the voltage input to the desired value and the VERTICAL GAIN for the desired amount of deflection. Keep in mind that the AC voltmeter reads RMS values which

are only .707 of the peak values. See figure 4. And the peak values are one-half the peak-to-peak values. Therefore, an RMS voltage input of .707 volts will result in a 2 volt peak-to-peak indication on the cathode ray tube.

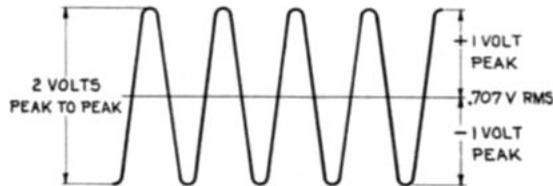

**FIG. 4. RELATED MEASUREMENTS OF VOLTAGE
IN A SINE WAVE**

One of these calibrators can be built as a permanent piece of equipment so the oscilloscope calibration can be determined and later checked. Calibration accuracy is dependent on tube amplification, and this will change as tubes age, or when they are replaced.



FIG. 5. SIMPSON MODEL 276 OSCILLOSCOPE CALIBRATOR

The Simpson Model 276 Oscilloscope Calibrator is now available for a simplified calibration procedure. It is an accessory which can be connected directly to the cable leading to the VERTICAL INPUT jack. There are binding posts on the Calibrator to which the signal input is connected. A switching arrangement in the Calibrator simplifies the entire calibration process. The deflection due to the signal can be duplicated, through a wide range of values, with a deflection due to a measured voltage, and the value can be read directly on the meter on an RMS, PEAK, or PEAK-TO-PEAK scale as desired.

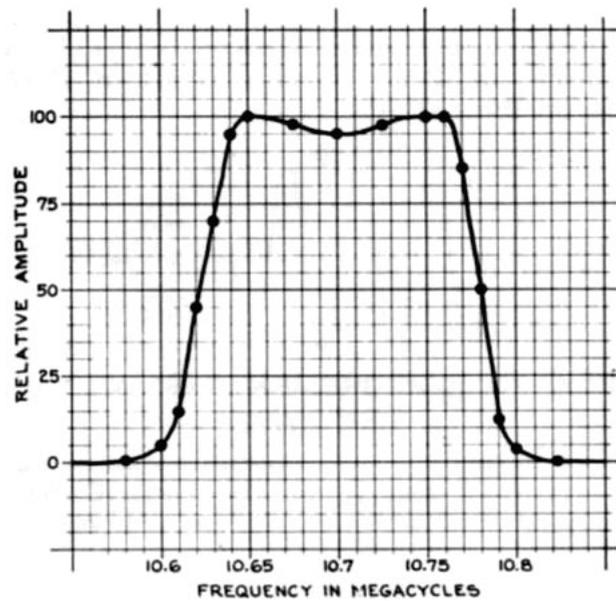

FIG. 6. GRAPHIC REPRESENTATION OF A RESPONSE CURVE

PRINCIPLES OF VISUAL ALIGNMENT

The visual method of adjusting resonant circuits has been developed in order to eliminate the tedious procedure of point by point measurements which would otherwise be necessary to determine the response characteristics of a tuned circuit or a number of tuned circuits such as used in radio and television receivers.

Referring to figure 6 it is obvious that a response curve can be traced by applying a signal of fixed amplitude to the input of the circuit and measuring the output voltage as the frequency of the generator is varied. This, of course, requires numerous measurements and is impractical for the purpose of circuit adjustment. The visual alignment procedure accomplishes the same result, but is instantaneous. Here the generator frequency is varied above and below circuit resonance at a fixed rate.

The vertical amplifier of the oscilloscope is connected across the output of the circuit in order to indicate the instantaneous voltage appearing at various points along the curve and the oscilloscope sweep is synchronized with the generator frequency deviation in such a manner that the entire resonant characteristic of the circuit is registered on the oscilloscope screen.

By this method the operator can see instantly the effects of the adjustments as he proceeds with the alignment.

This type of alignment is of particular value in television receivers because of the wide band characteristics necessary for satisfactory reception.

ALIGNMENT PROCEDURE

It would be impossible to cover all of the various alignment procedures in this manual since each receiver manufacturer determines the sequence of adjustment best suited to his particular product.

IMPORTANT. Follow the receiver manufacturer's service instructions when making adjustments on television receivers.

The following paragraphs will explain the various steps in the alignment of a typical

receiver, and may be used as a guide for adapting the GENESCOPE to any manufacturer's specific instructions.

The general procedure is as follows:

1. Connect the GENESCOPE to a 110 volt 60 cycle power outlet.
2. Turn the POWER switch to the OPERATE position.
3. Connect the receiver to a power outlet and turn on the power. Adjust the contrast control to about 3/4 of maximum. Some receivers require a battery bias to simulate normal AGC.
4. Allow the receiver and the GENESCOPE to warm up for about 15 minutes before attempting to make any adjustments. (The GENESCOPE will not require the warm up period if the POWER switch has been left in the STAND BY position for at least 15 minutes.)
5. Set VERTICAL SENS. at HIGH, VERTICAL GAIN at 0, HORIZ. GAIN at about 3, and FUNCTION switch at 60~ SWEEP. Adjust the INTENSITY and FOCUS controls, VERTICAL CENTERING, HORIZ. CENTERING, and HORIZ. GAIN controls for a thin bright centered trace with a satisfactory length.
6. Set the F.M. GENERATOR RANGE switch at OFF, the A.M. GENERATOR RANGE switch at B, the SIGNAL switch at CAL., the SIGNAL ATTENUATORS to a low setting, and VERTICAL GAIN at about 6.
7. Assume that the first adjustment specified in the manufacturer's literature is that of the adjacent channel video carrier trap at 19.75 mc. Follow instructions given in CALIBRATION PROCEDURES in this manual and determine the exact setting for 19.75 mc. Record the logging scale reading for future reference. It is good practice to determine the dial settings for all frequencies specified in the alignment instructions before proceeding with the adjustment; thus the alignment can be carried through without interruption. The frequencies specified in this example are; 19.75, 21.25, 21.8, 22.3, 23.4, 25.2, 25.3, and 27.25 mc. See figure 7. A new tendency among receiver manufacturers is to use an intermediate frequency centered around 45 mc.

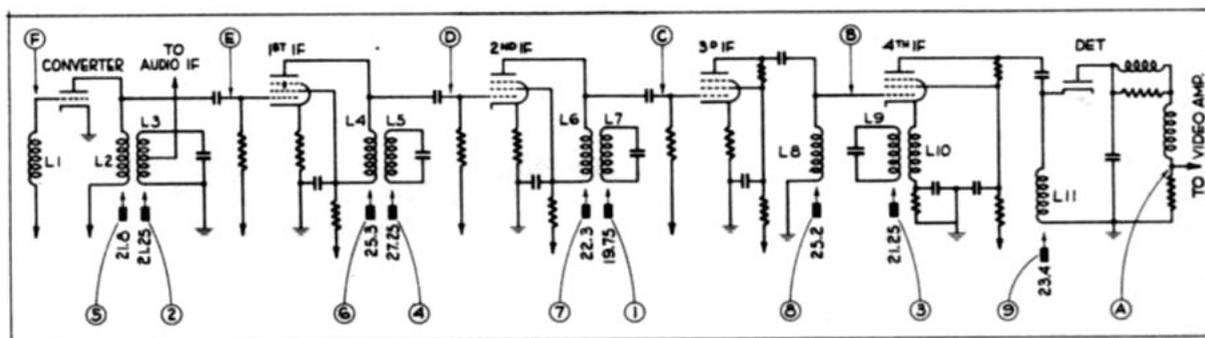

FIG. 7. TYPICAL TV PICTURE IF SYSTEM

8. Set the OUTPUT cable termination for 75 ohms by jumpering terminals 6-7-8-9-5 and terminals 2-3-4 (Open termination may be preferred. See Table 2 for instructions.) Connect the alligator clip on the end of the probe to point "F" of figure 7. Connect the ground lead of the probe to the receiver chassis. Connect the VERTICAL INPUT cable to point "A" of figure 7. Note that the ground lead and alligator clip may provide too much inductance for use at 45 mc. See the special instructions on page 27

9. Rotate the SIGNAL switch to MOD. R.F. and adjust the SIGNAL ATTENUATORS and VERTICAL GAIN until a good size Lissajou pattern is seen on the oscilloscope. The SIGNAL ATTENUATORS should be used at the lowest setting that will give a good oscilloscope pattern.

10. Set the A. M. Generator logging scale to the point recorded for 19.75 mc. and adjust L7 (point "1" in figure 7) for minimum pattern height. If the pattern disappears completely, increase the attenuator setting until the exact minimum point can be observed on the cathode ray tube.

11. Set the logging scale to the point recorded for 21.25 mc. and adjust the sound take off trap L3 (point 2) for a minimum indication.

12. Leave the Generator set for 21.25 mc. and adjust the accompanying sound trap L9 (point 3) for a minimum indication.

13. Set the logging scale to the point recorded for 27.25 mc. and adjust the adjacent channel sound trap L5 (point 4) for a minimum indication. This completes the trap adjustments.

14. Set the logging scale to the point recorded for 21.8 mc. and adjust the converter output L2 (point 5) for a maximum indication. If the pattern becomes too large reduce the SIGNAL ATTENUATORS.

15. Set the logging scale to the point recorded for 25.3 mc. and adjust the first IF L4 (point 6) for a maximum.

16. Set the logging scale to the point recorded for 22.3 mc. and adjust the second IF L6 (point 7) for a maximum.

17. Set the logging scale at the point recorded for 25.2 mc. and adjust the third IF L8 (point 8) for a maximum.

18. Set the logging scale at the point recorded for 23.4 mc. and adjust the fourth IF L11 (point 9) for a maximum.

19. If coils L2, L4, and L6 have required appreciable adjustment, the associated traps L3, L5 and L7 should be rechecked as explained in steps 10, 11, and 13.

20. Occasionally a receiver will have a tendency to oscillate during alignment. Usually this is caused by two or more transformers being tuned to the same frequency. Such oscillation will be identified by a sudden high deflection on the cathode ray tube and a scrambled pattern which cannot be controlled by the attenuators. When this occurs, the best remedy is to shunt points C, D, E, and F with .001 mfd capacitors. Connect the OUTPUT cable of the GENESCOPE to point B and adjust L11. Remove the capacitor at point C, Connect the OUTPUT cable at point C, and adjust L8. Repeat this process for each stage back to point F, Removing the capacitor and connecting the OUTPUT cable to points D, E, and F. Adjust L6, L4, and L2 for maximum indications. Some manufacturers recommend the latter, or backwards, sequence of adjustment. It makes little difference which sequence is used as long as each stage is adjusted carefully to its assigned frequency. This completes the i-f adjustments.

21. Leave the OUTPUT cable of the GENESCOPE connected to the converter grid (point F) and the VERTICAL INPUT cable connected across the video detector load resistor (point A).

22. Set the SIGNAL switch to the OFF position. Set the F.M. GENERATOR RANGE

switch to A, F. M. ATTENUATOR switch to MAX. and potentiometer to 5, PHASING to 0, and BLANKING to OFF. Tune the F. M. Generator to approximately 23 mc. on range A. A response curve of the i-f system should appear on the oscilloscope. Adjust the F. M. ATTENUATORS and VERTICAL GAIN for a pattern of convenient height, keeping the F. M. ATTENUATORS set as low as possible. Adjust the PHASING control to superimpose the two traces. Readjust the tuning dial until the response pattern is centered on the trace. Readjust the F. M. SWEEP control until the pattern includes about two-thirds of the horizontal trace. Correct the PHASING control for superimposed traces again. Rotate the BLANKING control to produce a base line through a single trace.

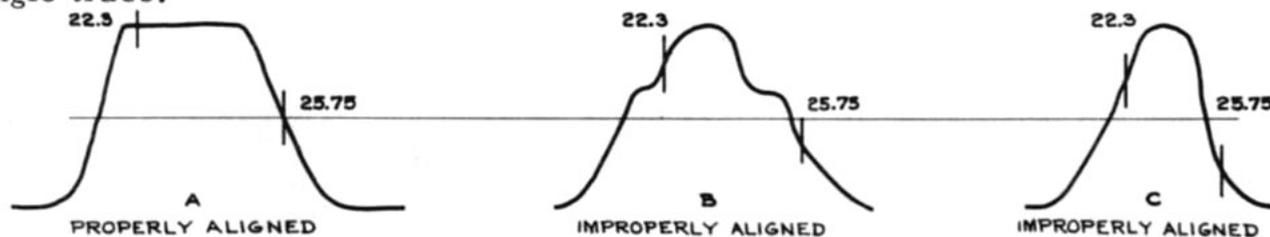

FIG. 8. PICTURE IF RESPONSE - STAGGER TUNED

23. Compare the pattern with the one shown in the manufacturer's instructions. Figure 8 shows an example of an i-f response curve. If the system has been aligned properly, the pattern should resemble figure 8A.

24. Turn the SIGNAL switch to UNMOD. R.F. and set the logging scale of the A. M. Generator to the point for 22.3 mc. A marker should appear on the pattern as shown on the left in figure 8 A, B, and C. Adjust the SIGNAL ATTENUATORS and the F. M. ATTENUATORS for the desired balance of signal strengths. If the marker is too strong, the curve will be distorted and it will be difficult to measure its exact position on the pattern.

25. Set the logging scale to the point recorded for 25.75 mc. and check the position of the marker. It should appear at 50% of the maximum pattern height. Setting the marker frequency to the various points to which the system was adjusted will indicate the part of the response curve affected by each adjustment. Slight readjustment of the system may be performed at these points in order to produce a satisfactory response curve. However, if considerable adjustment is necessary, the entire alignment procedure should be repeated.

The foregoing paragraphs have dealt with the alignment of a stagger tuned Video IF system. Another system, known as Band Pass IF, which is used in many receivers, requires that the entire alignment be performed by use of the FM Generator. In this type of receiver the alignment begins with the last IF stage and proceeds back to the converter. A set of curves is furnished as a guide and it is only necessary to follow the sequence set up by the manufacturer's instructions using the curves to indicate the type of response to be expected. A set of such curves is shown in figure 9.

To adjust band pass i-f, connect the VERTICAL INPUT cable to the video detector output and the OUTPUT cable to the grid of the last i-f amplifier stage. Set the F. M. GENERATOR RANGE switch to A and adjust the dial to 25 mc. Set the F. M. ATTENUATORS to MAX. and 10, and adjust the VERTICAL GAIN, PHASING, and BLANKING controls for a single image pattern with satisfactory height. Set the A. M. GENERATOR RANGE switch to B and the SIGNAL switch to CAL. Record logging scale markings for 22.6, 22.75, 23.25, 23.75, 24.25, 24.6, 25.75, 26.6, 26.75, 27.0 and 27.1 megacycles. Set the SIGNAL switch to UNMOD. R.F. and the logging scale to the point recorded for 27.1 mc. Adjust the SIGNAL ATTENUATORS to the lowest setting which will give a satisfactory marker on the trace. Adjust the last i-f transformer primary and secondary for a single peak centered on the 27.1 mc. marker. Set the A. M. Generator

logging scale to the position for 23.25 mc. Adjust the coupling condenser in the last i-f transformer for a peak centered at 23.25 mc. The curve should now resemble figure 9A.

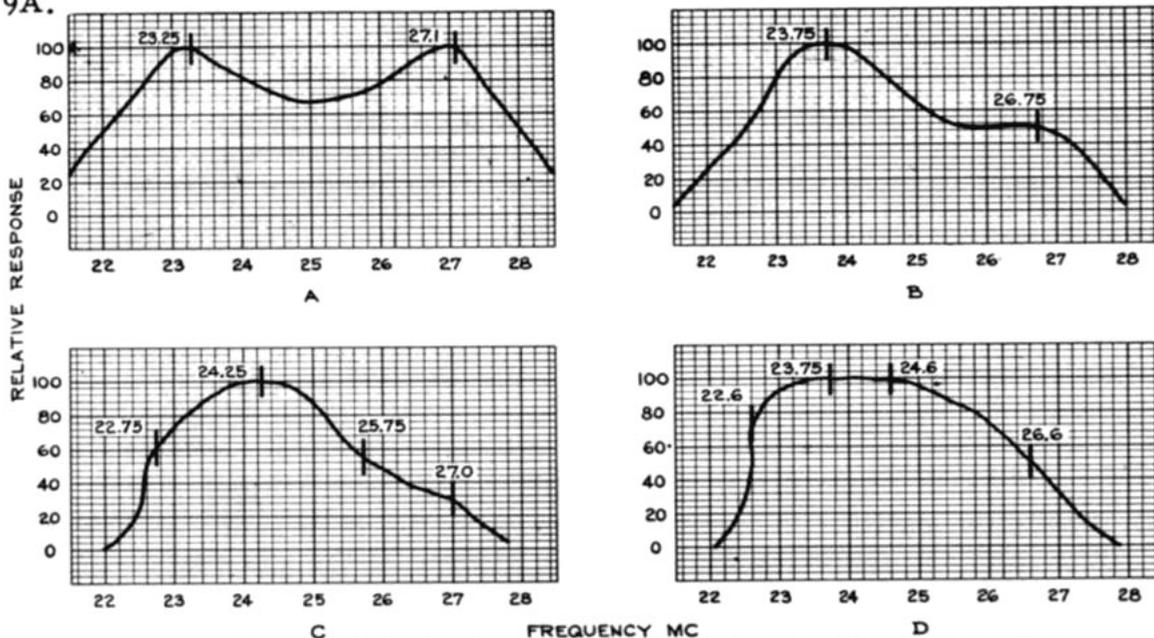

FIG. 9. PICTURE IF ALIGNMENT CURVES—BAND PASS TYPE

Move the OUTPUT cable to the grid of the preceding stage. Adjust the secondary of this i-f transformer for a peak at 23.75 mc. and the primary for a peak at 26.75 mc. There is no coupling condenser adjustment for this stage. The curve should now resemble figure 9B.

Move the OUTPUT cable to the next preceding stage. Adjust the primary and secondary for a curve having the same shape and relative amplitude as that of figure 9C. Use the marker at the frequencies indicated: 22.75, 24.25, 25.75, and 27.0 mc.

Move the OUTPUT cable to the grid of the converter and adjust the primary, secondary, and coupling condenser of the first i-f transformer for a curve having the same shape and relative amplitude as figure 9D. The check points indicated for marker use are 22.6, 23.75, 24.6, and 26.6 megacycles.

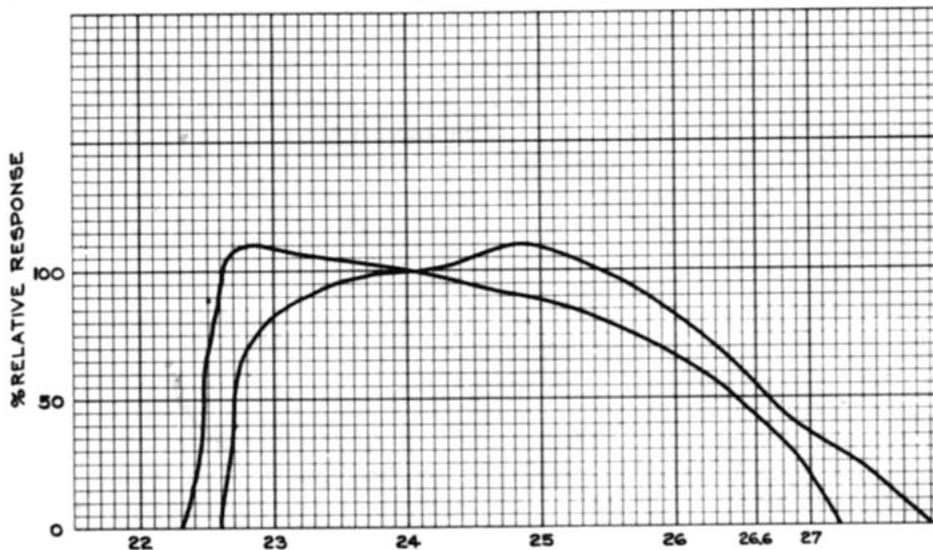

FIG. 10. RESPONSE TOLERANCE—BAND PASS IF

Touch up adjustments are permissible to improve the over-all response curve. Be careful to select the adjustment which affects the part of the curve which needs correction. Figure 10 shows the acceptable limits of the over-all response curve with the amplitude at 24.0 mc. for a reference point. Conduct the alignment to produce a curve which is within these tolerances.

The last five paragraphs have dealt with the alignment of an i-f response curve only. For trap adjustments, see steps 7 to 13 on page 15. The trap adjustments should be made in the order recommended by the receiver manufacturer, with the F. M. GENERATOR RANGE switch in the OFF position and the SIGNAL switch in the MOD. R.F. position. Log the specified trap frequencies in advance.

A third type of circuit uses what is known as intercarrier i-f. The principle is to provide a mixer and oscillator to produce an intermediate frequency, and to amplify this i-f through several stages with a special frequency response characteristic; the band pass is sufficient to include both the sound and the video center frequencies, and the response maintains a desired relative amplitude between the two center frequencies. Then the beat of 4.5 mc. between the two center frequencies is used to produce a double superheterodyne action with the sound frequency modulated on the 4.5 mc. carrier. The sound i-f (usually one stage), tuned to 4.5 mc., amplifies the sound signal and sends it to an f-m demodulator of any type desired by the manufacturer. It is important to follow the alignment data indicated in the manufacturer's literature because he has engineered a circuit which requires specific response characteristics and no generalization could represent the large variety of possibilities. The receiver manufacturer's literature will indicate where the test points are located, what frequency to use for each input, what adjustment can be made, and the resulting response wave shape. Set up the GENESCOPE in accordance with the general instructions. Use the 60 cycle sweep in the oscilloscope and observe the response curve in phase with the frequency modulating signal.

Sometimes during alignment it is desirable to have two markers at different frequencies on the response curve at the same time. A second signal generator, unmodulated, is necessary, tunable to the frequency at which the marker is desired. The second generator can be calibrated with the accuracy of the GENESCOPE and should be as stable as possible. To calibrate the second generator, set up the GENESCOPE for its normal alignment procedure, with the OUTPUT cable feeding the signal into a receiver and the receiver output connected to the VERTICAL INPUT cable. Establish the marker on the response curve at the frequency to which the second generator will be tuned. Then couple the second signal generator output across the termination box or in any other convenient way to the receiver input. Sometimes the mere presence of the second generator on the test bench will provide sufficient coupling without any direct connections. Now tune the second signal generator for a beat indication with the marker from the accurately calibrated A. M. Generator in the GENESCOPE. Tune the second generator for a zero beat indication of the two markers. Then change the setting of the GENESCOPE A.M. Generator to provide the second marker frequency. Both markers will show on the single response curve.

F-M RECEIVER ALIGNMENT

The order of f-m alignment usually begins with the discriminator adjustment; the i-f section is next and the r-f section is last. If the receiver manufacturer recommends some other sequence, use his suggestions rather than these general instructions. The information in the following paragraphs is for the sound section of a television receiver, but the same principles apply to f-m receivers except that their intermediate frequencies are usually lower.

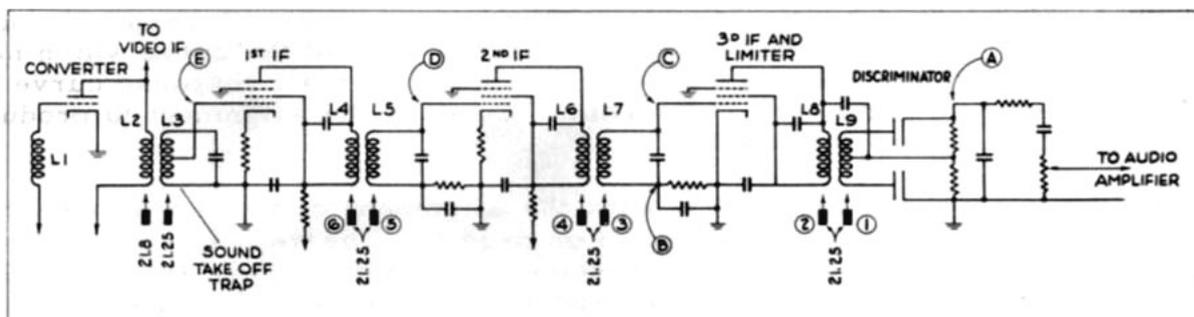

FIG. II. TYPICAL TV SOUND I-F SYSTEM

Figure 11 is the schematic diagram of a typical sound i-f system composed of three i-f amplifier stages and a discriminator. The third i-f stage acts as a limiter to reduce the effects of amplitude modulations.

1. Connect the **GENESCOPE OUTPUT** cable between point "C" of figure 11 and ground. Use a 75 ohm, 300 ohm, or open termination as desired. See table 2 for data on the termination connections. Use the series condenser (do not jumper terminals 1 and 6).

2. Connect the **VERTICAL INPUT** cable between point "A" of figure 11 and ground.

3. Set the **F.M. ATTENUATOR** switch to **MAX** and the potentiometer to 10, **F.M. SWEEP** to 1, **PHASING** to 0, **BLANKING** to **OFF**, **F.M. GENERATOR RANGE** to **A**, and **CENTER FREQUENCY** dial pointer to 21.25 mc. (the intermediate frequency).

4. Set the **VERTICAL SENS.** switch to **HIGH**, **VERTICAL GAIN** to 0, **FUNCTION** to 60~ **SWEEP**, and the other oscilloscope controls for a clear bright trace about two inches long, centered horizontally and vertically.

5. Advance **VERTICAL GAIN** until the pattern is about one inch high. The pattern will be two S-shaped response curves. Adjust the **PHASING** control to bring the curves in phase as shown in figure 12.

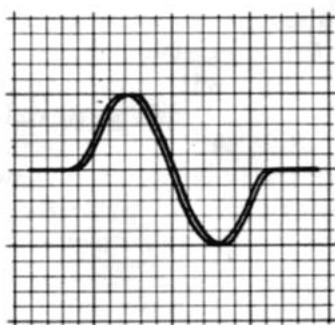

FIG. 12. DISCRIMINATOR RESPONSE - IN PHASE - BLANKING OFF

6. Adjust **F.M. SWEEP** so the response curve covers most of the horizontal trace as shown in figure 12. Readjust the **PHASING** if the traces are not superimposed. If the response curve is not centered on the trace, reset the **CENTER FREQUENCY** pointer to center the pattern. Advance the **BLANKING** control to produce a pattern as shown in figure 13; a single curve with a base line through it.

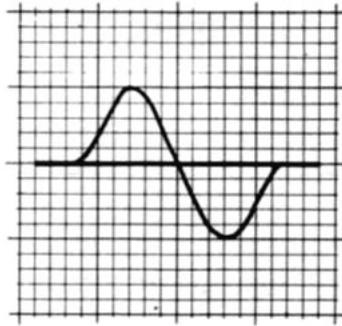

FIG. 13. DISCRIMINATOR RESPONSE – BLANKING ADJUSTED

7. Reduce the F.M. ATTENUATORS and advance the VERTICAL GAIN for the lowest attenuator setting which gives a satisfactory pattern.

8. Set the SIGNAL switch to CAL., A.M. GENERATOR RANGE to B, SIGNAL ATTENUATORS to a low setting, and adjust the frequency to exactly 21.25 mc. (see CALIBRATION PROCEDURES, page 9).

9. Turn the SIGNAL switch to MOD. R.F. A pattern similar to figure 14 will appear on the oscilloscope if the discriminator secondary is not aligned perfectly. Reduce the SIGNAL ATTENUATORS to as low a setting as possible with the 400 cycle pattern still showing.

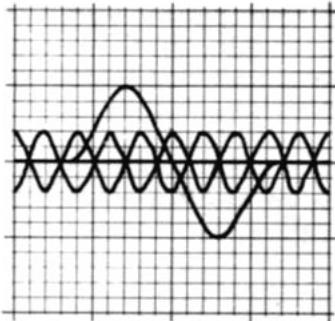

FIG. 14. DISCRIMINATOR RESPONSE – 400 CYCLE MODULATION

10. Adjust the discriminator secondary (L9 in figure 11) until the 400 cycle pattern disappears and then reappears if the adjustment is continued in the same direction. Be sure to make this adjustment to the exact null point with the SIGNAL ATTENUATORS set low to avoid a broad response due to a high signal amplitude.

11. Adjust the discriminator primary (L8 in figure 11) until a maximum amplitude symmetrical pattern is achieved as shown in figure 13. Reduce the F.M. ATTENUATORS as the amplitude of the curve increases. Recheck the secondary adjustment if the 400 cycle pattern re-appears.

12. Move the OUTPUT cable to the grid of the next preceding stage (point D in figure 11).

13. Move the VERTICAL INPUT to the grid of the limiter (point C in figure 11).

14. Turn the SIGNAL switch to UNMOD. R.F. and adjust the F.M. and SIGNAL ATTENUATORS to obtain an i-f response curve similar to figure 15. The curve may be distorted until the next adjustment has been made.

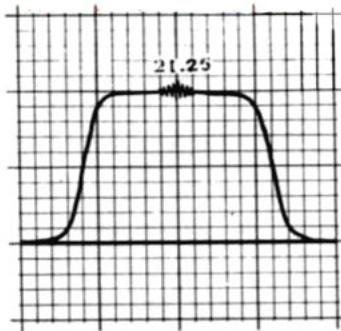

FIG. 15. SOUND IF RESPONSE

15. Adjust L7 and L6 of figure 11 for a symmetrical response of maximum height similar to figure 15. The marker should appear at the center. Keep the F. M. ATTENUATORS set as low as possible to avoid overloading and keep the SIGNAL ATTENUATORS low to avoid distortion of the response curve at the marker point.

16. Connect the OUTPUT cable to the grid of the next preceding stage (point E of figure 11). Adjust L5 and L4 for a symmetrical response curve of maximum height as in step 15 above.

The sound adjustment is now complete. Adjustment of L2 and L3 was made during the video i-f alignment. However, if this were an f-m receiver instead of a television receiver, L2 and L3 would be adjusted to the receiver intermediate frequency in the same manner as the preceding adjustments with the OUTPUT cable coupled to the converter grid. As the alignment proceeds from the discriminator back to the converter, the width of the response curve will decrease since the selectivity of the entire amplifier is greater than that of any one stage. If the response curve becomes too small, reduce the F.M. SWEEP. Any change in sweep width will require re-adjustment of the PHASING control. Adjust the PHASING control with BLANKING at OFF.

If a check of the band pass of the i-f system is desired, connect the OUTPUT cable to the grid of the converter and move the marker (with the A.M. Generator) from one side of the response curve to the other.

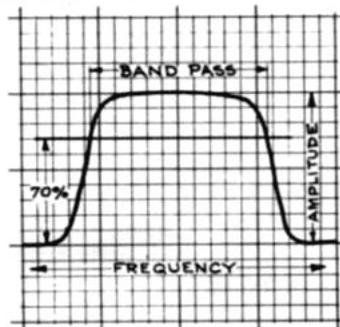

FIG. 16. IF BAND PASS MEASUREMENT

The band pass of a resonant circuit is usually taken between the 70% response points. See figure 16. To check the band pass of the i-f system, set the A.M. Generator tuning knob to place the marker on the response curve at the 70% point on one side of the curve. Record the setting of the logging scale. Then move the marker to the 70% point on the opposite side of the response curve and record the logging scale setting. Translate the logging scale settings to frequencies as explained in CALIBRATION PROCEDURE. Use the following formula:

$$F_1 = F_2 \left(\frac{D_1}{D_2} \right)$$

- where F_1 = frequency difference between the desired frequency and a crystal check point,
- F_2 = frequency difference between two crystal check points surrounding the desired frequency.
- D_1 = logging scale divisions between the desired frequency setting and the same crystal check point (see F_1 above),
- and D_2 = logging scale divisions between the same two crystal check points (see F_2 above).

Then subtract the lower frequency from the higher for the band of frequencies "passed". However, if such accuracy is not required, read the frequencies directly from the appropriate range on the A.M. Generator dial.

TELEVISION TUNER ALIGNMENT

Many of the present day television sets use an r-f tuning unit produced by Standard Coil Products Co. This unit contains a 12-position rotary channel selector together with a stage of r-f amplification, an r-f oscillator, and an r-f mixer. The components are matched for the purpose of transferring the modulation on the tuned signal to an intermediate frequency. The various receiver manufacturers who use this tuner have used slightly different center intermediate frequencies, and some have used separate i-f strips for sound and video, while others have used intercarrier i-f amplification. The tuner can be adjusted to produce whatever output the manufacturer requires for his circuit, and manufacturer's literature will indicate the center frequency and the wave form required for servicing his equipment.

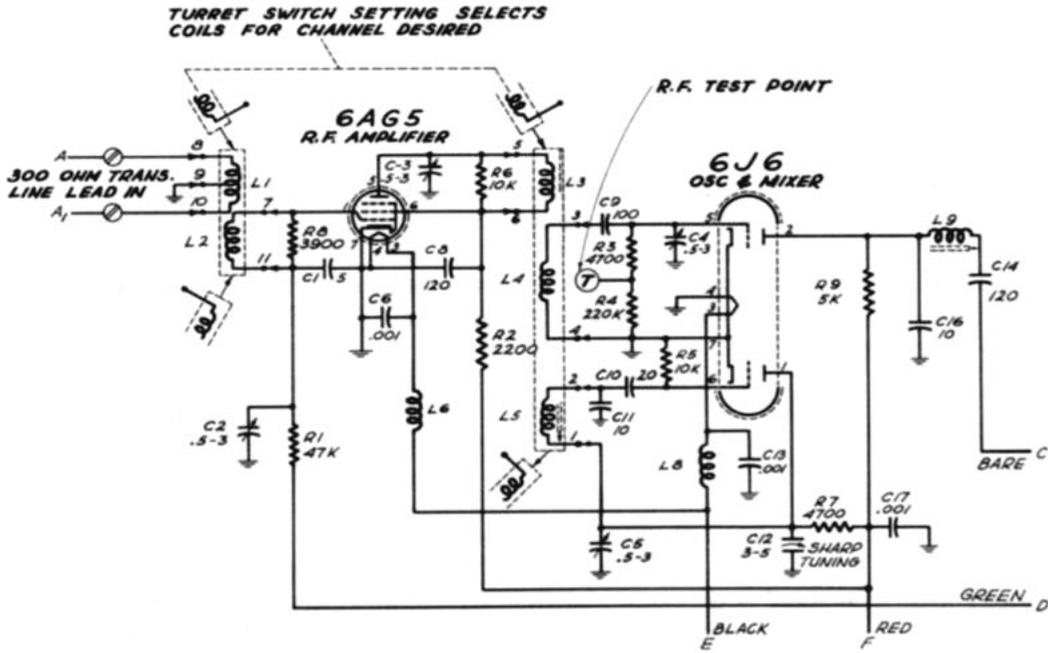

FIG. 17. STANDARD COIL PRODUCTS TUNERS

A. CIRCUIT FOR TV-114, 214, 293

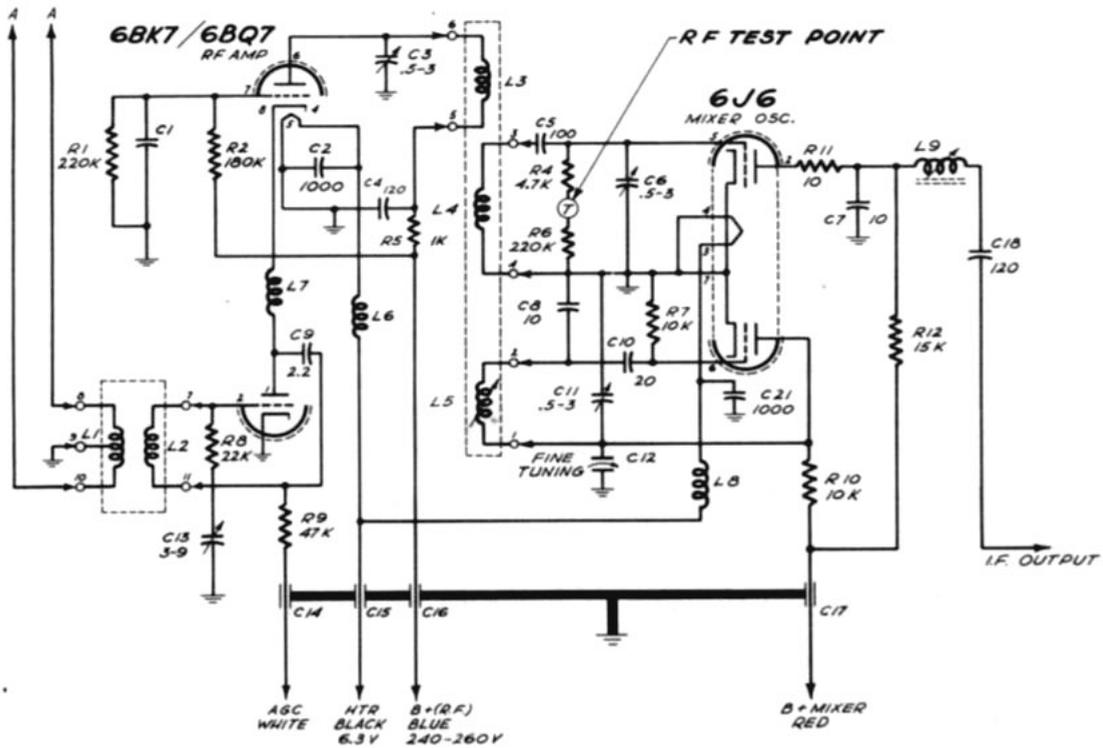

FIG. 17. STANDARD COIL PRODUCTS TUNERS

B. CIRCUIT FOR TV-2000 SERIES

Admiral Corporation, for an example, uses the Standard Coil Products tuner diagrammed in figure 17A in their 21B1, 21C1, and 5D2 chassis. It is adjusted to tune, in the r-f amplifier, a double peaked curve with the center frequencies of the sound carrier and the video carrier at the peaks and not more than 30% reduction in response to frequencies within this 4.5 mc. range. Then the intermediate frequency output is balanced so that after it has passed through the i-f amplifiers, the center video carrier is on one slope of the curve at a 50% response point, and the center sound carrier is on the other side of the curve at a 5% response point. The same pair of wave shapes need to be produced for each of the 12 channels. Each channel has a pair of tuned circuits with switch points which make all the necessary connections to tune both the received signal and the local oscillator for the frequencies necessary for the channel. The tuning problem consists of adjusting slugs for each of the 12 bands which insure that the maximum signal strength, with proper amplitude proportions for its component frequencies, will come out of the mixer.

In general, the manufacturer will specify an input across the antenna terminals at the center frequency of the channel, frequency modulated through a range of 10 megacycles or more, and marked at the video carrier frequency and the sound carrier frequency. Use the OUTPUT cable for this connection and set the termination box for the characteristic impedance of the antenna terminals (see table 2). Connect the VERTICAL INPUT cable at the r-f test point on top of the tuner chassis between the two tubes. The circuit position for this test point shows in figure 17A and B. Adjust the r-f stage tuning. Then move the VERTICAL INPUT cable to the next specified check point (probably in the i-f amplifier) and adjust the oscillator tuning for the specified response curve.

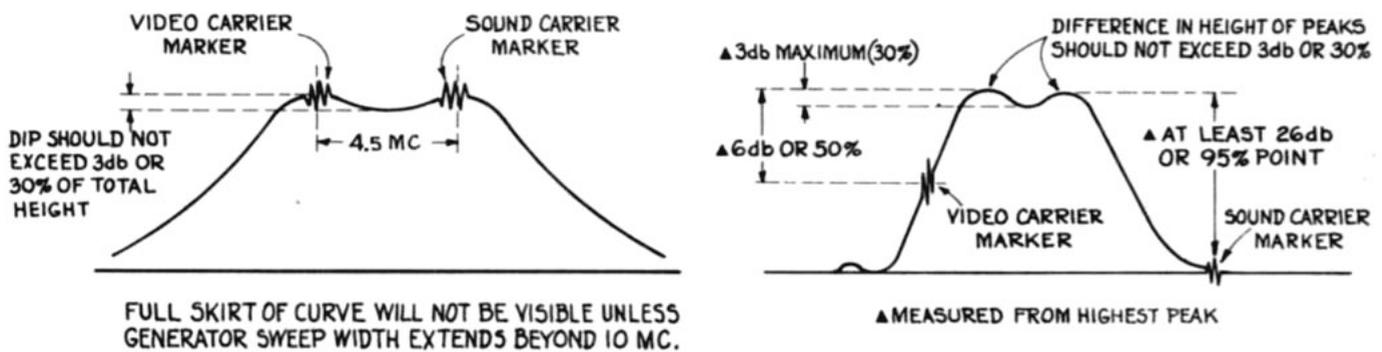

FIG. 18. TYPICAL TV TUNER RESPONSE

A. R. F. RESPONSE

B. OVERALL R. F. AND I. F. RESPONSE

F. M. TUNER ALIGNMENT

Frequency modulation receivers have the following sections: r-f tuner, oscillator, mixer, i-f amplifier, limiter, discriminator, and a-f amplifier. The procedure for aligning the i-f amplifier, limiter, and discriminator is identical to the procedure for the sound section of a television receiver except that the intermediate frequency for f-m receivers is usually 10.7 mc. See pages 20 to 22 for this data.

The general type of instructions for adjustment of the r-f tuner, oscillator, and mixer can be outlined but the exact and complete procedure will vary from one manufacturer to another. Most receivers have provision for adjustment near the high end of the dial (108mc.). Some have a low frequency adjustment in addition. It is advisable to consult manufacturer's literature to obtain recommended frequency or frequencies.

1. Connect the VERTICAL INPUT cable across the output of the demodulator stage (point "A" in figure 11).
2. Connect the OUTPUT cable through its matching network to the antenna terminals of the receiver. Connect the termination box according to the data in table 2 to provide the correct input for the receiver. Manufacturer's instructions should indicate whether this is 75 ohms or 300 ohms.
3. Set the A.M. GENERATOR to the frequency recommended for alignment. Set the receiver dial to the same frequency.
4. Rotate the SIGNAL switch to MOD. R.F. and adjust the SIGNAL ATTENUATORS, F.M. ATTENUATORS, and VERTICAL GAIN for a 400 cycle pattern with satisfactory height.
5. Adjust the oscillator, mixer, and r-f trimmers of the receiver to obtain a maximum amplitude pattern. Keep the SIGNAL and F.M. ATTENUATORS as low as possible, but keep a usable pattern on the cathode ray tube.

An alternate to the above method uses a frequency modulated signal input to the antenna, with a marker signal set at the desired frequency. Adjust the oscillator, mixer, and r-f trimmers of the receiver for a symmetrical response curve with a maximum amplitude and with the marker centered on the curve.

Note that these instructions are very general. They are intended as a theoretical idea of alignment only. Always consult the receiver manufacturer's instructions for specific directions when aligning his sets and follow them. However, the oscilloscope section of the GENESCOPE can be used to advantage in place of, or in addition to, a vacuum tube voltmeter. The oscilloscope will identify the shape of the wave form as well as its amplitude.

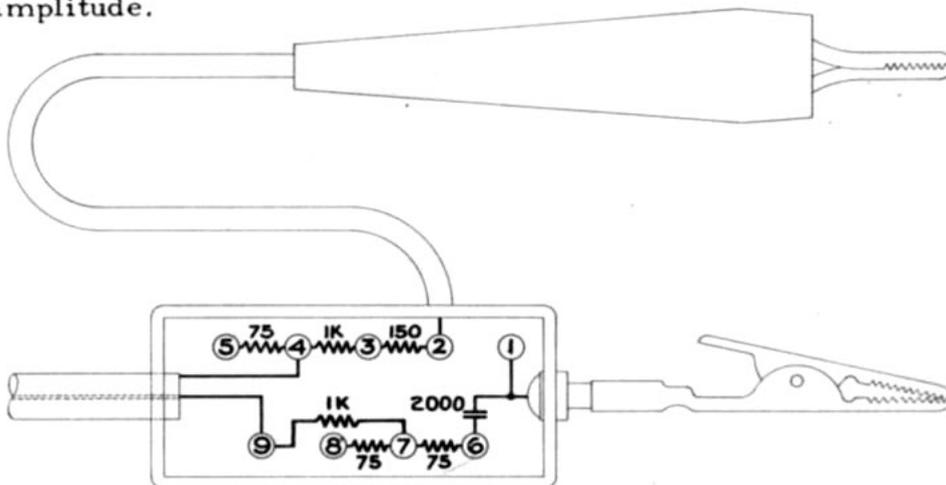

FIG. 19. IMPEDANCE MATCHING OUTPUT CABLE

TABLE 2. TERMINATION BOX CONNECTIONS

TERMINATION	CONNECTIONS	
300 OHMS	JUMPER 7-8-9-5	JUMPER 3-4
300 OHM WITH PAD *	JUMPER 3-8	JUMPER 5-9
75 OHMS	JUMPER 6-7-8-9-5	JUMPER 2-3-4
75 OHM WITH PAD *	JUMPER 6-7	JUMPER 2-3-8
OPEN TERMINATION	JUMPER 2-3-4	JUMPER 6-7-8-9
SERIES CAPACITOR	NO JUMPER 1-6	USE IN ADDITION TO TERMINATIONS INDICATED ABOVE.
RESISTANCE COUPLING.	JUMPER 1-6	
NO SERIES CAPACITOR		

*THE USE OF A PAD PROVIDES 1000 OHMS IN SERIES WITH EACH SIDE OF THE LINE

USING OUTPUT CABLE TERMINATION BOX

In order to simulate actual operating conditions, it is important that the receiver input impedance and the generator output impedance are matched. The OUTPUT cable for the GENESCOPE has a termination box built on the probe end to facilitate matching these impedances. See figure 19 and table 2 for an outline drawing of the probe and some of the possible connections. The two most commonly used impedances for receiver inputs are 75 ohms and 300 ohms. These are both available, with or without an isolating pad, by simply connecting bare wire jumpers as indicated in table 2. In each case except open termination, the connections are set to provide a 75 ohm termination for the GENESCOPE output because this value is proper for its output characteristics. Use of the pad provides isolation between the output of the GENESCOPE and the receiver points to which it is connected. If a series capacitor of 2000 uuf is desired in series with the receiver input for d-c blocking, do not jumper terminals 1 and 6, but if a straight resistance coupling is desired, jumper these terminals to short the capacitor which is built into the termination box. An open termination is provided for optional use: when using this connection, the GENESCOPE output is not impedance matched, but each side of the output is connected straight through (with the series capacitor if desired) to the two sides of the receiver input.

When operating in the new intermediate frequency range around 45 mc., the termination box may cause distortion of the response wave form. For best results, change the termination box connections as follows:

1. Pull the alligator clip off the post on the end of the termination box near screw terminal number 1.
2. Cut two pieces of solid bare jumper wire, #20 or 22, 1-3/4 inches long and one piece 1 inch long.
3. Loosen screws 2, 3, and 4, and place one 1-3/4 "wire under them so that it is straight between the screws and then bends around screw number 2 with about 1/2 inch extending beyond the side of the termination box. Tighten the screws. This will be the ground lead.
4. Loosen screws 6, 7, 8, and 9. Place the other 1-3/4" wire under these screws. Keep the wire straight and tighten the screws.
5. Loosen screw number 1 and place one end of the 1" wire under it. With the wire extending off the side of the termination box, tighten the screw. This will be the "hot" lead.
6. Solder the "hot" lead to the connection point of the receiver and the ground lead to the chassis or receiver ground.

This provides an open termination for the cable, with the 2000 uuf capacitor in series. It is important to keep the leads of the probe very short to obtain efficient operation.

An alternate method of handling this problem is to make up a special output cable to use for 45 mc. An Amphenol type 80M cable connector, about 3 feet of RG-59/U cable, and a 1000 uuf or 2000 uuf ceramic capacitor are all the required parts. Attach the connector on one end of the cable and solder one lead of the capacitor (clip the lead

short) to the center conductor at the other end of the cable. Solder the other capacitor lead to the connection point in the receiver and the cable shield to the chassis or receiver ground.

A special OUTPUT cable assembly, Simpson part number 10-830046, for use at 45 mc., is now available as an accessory to owners of the GENESCOPE.

Should other combinations be desired, they may be obtained by using resistors between the terminals rather than using jumper wires. Suppose 150 ohms were desired. Connect a jumper across terminals 5 and 9 to provide the proper termination for the Model 479. Then connect a 75 ohm resistor from terminal 6 to terminal 7, a jumper from 7 to 8 to 9, a jumper from 3 to 4, and a 50 ohm resistor between terminals 2 and 3. If a pad is desired, leave the jumpers off of terminals 7-8-9 and terminals 3-4 and put in a jumper between terminals 3 and 8. Unlimited possibilities of terminations can be produced by this method of combining the resistances inside the termination box with external resistance.

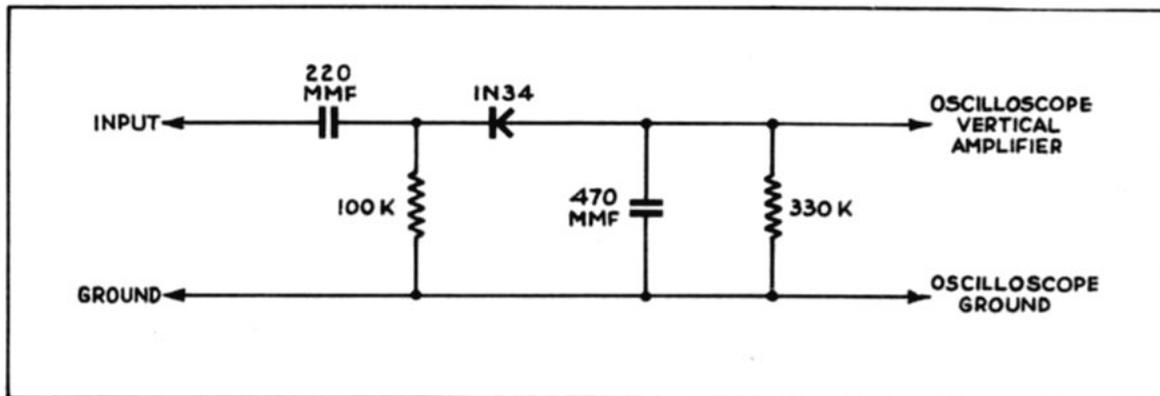

FIG. 20. SCHEMATIC OF THE HIGH FREQUENCY PROBE

SIGNAL TRACING

Figure 20 shows the arrangement of components in the high frequency probe. Connect this probe to the VERTICAL INPUT of the oscilloscope to trace the signal through an f-m or television receiver. The probe is essentially a high frequency detector and it may be used to pick up the modulation on the signal from any part of the system where high frequencies exist.

To trace a signal through the sound channels of a television receiver or through an f-m receiver, connect the OUTPUT cable to the antenna terminals of the receiver and set the A.M. GENERATOR to the sound carrier frequency of the channel to which the receiver is tuned. Rotate the SIGNAL switch to MOD. R.F. Connect the high frequency probe cable to the VERTICAL INPUT jack and the ground lead to the receiver chassis. Starting at the grid of the converter, the signal may be picked up at each successive grid and plate through the i-f system. The 400 cycle modulation pattern should increase in amplitude as each successive stage is checked.

In a television receiver, the picture system may be traced in the same manner. Set the A.M. Generator to the picture carrier frequency and the SIGNAL switch to MOD. R.F. for this test. Trace the signal from the grid of the converter tube through the video i-f amplifiers, noting the increase in amplitude of the 400 cycle modulation pattern as each successive stage is checked.

Any single stage may be checked by connecting the OUTPUT cable across the input of the stage with the A.M. Generator set to the proper frequency for the stage. Contact the output of the stage with the high frequency probe.

TESTING THE AUDIO AMPLIFIER

The GENESCOPE contains a 400 cycle audio oscillator which can be used to test the audio amplifier section of a receiver. Set the SIGNAL switch at AUDIO. Use the OUTPUT cable and the SIGNAL ATTENUATORS. This feature is of special value when tests of the audio amplifier alone are desired.

To test the audio amplifier, connect the OUTPUT cable across the discriminator or detector output. Turn the volume control of the receiver to its full on position. With the SIGNAL switch in the AUDIO position and the SIGNAL ATTENUATORS and VERTICAL GAIN set for a satisfactory oscilloscope indication, connect the VERTICAL INPUT cable across the various points to be checked from the demodulator back to the speaker. Note the increase in signal strength as each successive stage is checked. Watch for distortion of the sine wave. Set the SIGNAL ATTENUATORS as low as possible to prevent overloading the vertical amplifier of the oscilloscope since this would give a false indication of distortion in the receiver.

For the best indication of the 400 cycle sine wave, set the FUNCTION switch at INT. SYNC., the SWEEP RANGE to 75-350~, and the RANGE FREQUENCY and SYNC. to positions which will show three or four cycles of the sine wave in a steady position.

CHECKING VIDEO AND SYNCHRONIZING WAVE FORMS IN A TELEVISION RECEIVER

NOTE: The following is reprinted from Radio Service Dealer. This paper, by Samuel Marshall, Managing Editor, is an excellent example of the practical application of the Cathode Ray Oscilloscope to Television Service.

Speed in servicing depends on how quickly a radioman can recognize the symptoms that appear or occur in defective receivers. These symptoms appeal to all of our five senses, namely of sight, smell, touch, taste, and hearing.

Thus a receiver that hums affects our sense of hearing, and generally indicates to us, because of previous similar experiences, an open filter. In the same manner, a receiver that has a tarry odor affects our sense of smell and usually indicates a defective power transformer. We can go on enumerating case after case of defects occurring in receivers--each one producing its own particular symptom--and each symptom revealing to us where the trouble lies.

Now, this process is nothing more than an application of the natural laws of memory, particularly those referring to cause and effect, except that in radio repairing we first observe the effect, on the basis of which we can generally guess the cause. Naturally, the more experience we have, the easier it becomes for us to connect certain effects and their causes.

All this is particularly true in television work. Being a comparatively new development, very few men have been able to build up a stockpile of TV experiences which would enable them to tell at a moment's glance what is wrong with a particular receiver. For this reason the sincere technician, the fellow who really wants to make a career of television, must do two things, and do them quickly. First, he must find out all there is to know about television, both theoretically and practically. Second, he must learn how to use and apply all of the different types of test instruments necessary in the testing and adjusting of TV receivers. Naturally,

at the frequencies contained within the channel to which it is assigned. Thus a station assigned to channel 2 contains carrier and sideband frequencies between 54 and 60 megacycles.

Fig. 22 shows a more detailed view of the front end and the waveshapes associated with it. Notice the waveshapes of the incoming signal at A and the converted

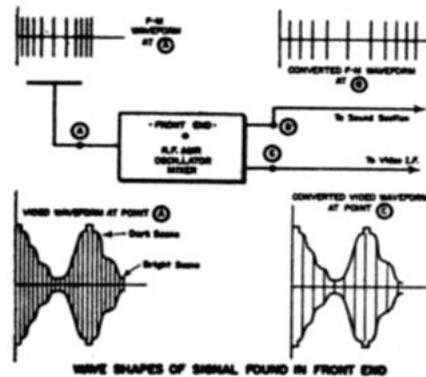

FIG. 22 AN AND FM WAVESHAPES

output signal waveshapes at B and C. At A the incoming signal contains two carriers and their sidebands, the FM and the video. Notice that the FM waveshape has a constant amplitude and a varying frequency. On the other hand the video waveshape has a varying amplitude and a constant carrier frequency.

An interesting point with respect to the video waveshape is that all sync pulses reach the same amplitude. The video portion of the signal, on the other hand, varies in amplitude according to negative transmission principles, that is, bright scenes have a low amplitude and dark scenes a high amplitude.

In the converted signal both FM and video signals have new carrier frequencies, the values of which are the i-f frequencies of the receiver. These frequencies being lower than the r-f, the wavelengths are wider as can be readily seen in the figure.

The FM section in most TV receivers is conventional and differs only from that

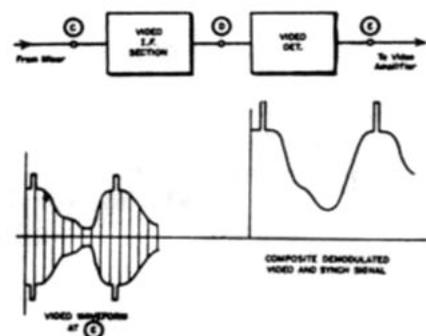

FIG. 23 VIDEO I.F. DET. WAVESHAPES

in an ordinary FM receiver by the maximum deviation frequency being 25 kc instead of 75 kc which is standard for FM. We will not elaborate on the FM section of the receiver for this reason.

Returning now to Fig. 21 we notice that the video output of the front end enters the video i-f section at C. This section is primarily concerned with the video picture signal and corresponds to the i-f section of a broadcast receiver. The output of this section feeds into a video detector. Fig. 23 illustrates these sections in greater detail.

The i-f section contains the various video i-f amplifiers and sound traps. The signal entering this section is the video i-f coming out of the mixer. The signal leaving the section at point E is the detected video output which contains the demodulated video picture signal and synch pulses.

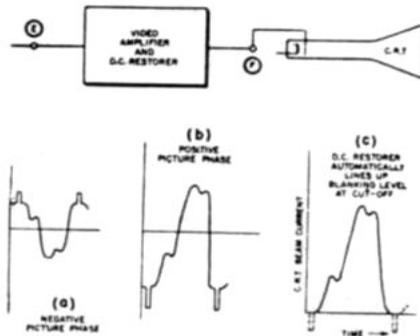

FIG. 24 VIDEO AMPLIFIER WAVESHAPES

Referring again to Fig. 21 we notice that the detected video and synch signal is fed into a fourth section which contains the video amplifier stage or stages, and the d-c restorer. The output of this section at point F divides into two paths, the first leading into the picture tube where the video and synch signal is converted into corresponding light variations, and the second into the horizontal and vertical synch amplifier and sweep sections. These will be discussed shortly in greater detail.

Fig. 24 illustrates the input and output waveforms of the video amplifier. Notice that the input signal curve (a) is essentially alternating current and that the picture phase, in this case, is negative. A negative picture phase simply means that bright scenes drive the signal negative and dark scenes drive it positive. The output of the video amplifier, if connected directly to the grid of the cathode ray tube must have a positive picture phase, or one in which the bright scenes drive the signal positive. This is shown in curve (b). Observe that the signal is still a.c.

In curve (c) we observe that the signal is no longer a.c. but a pulsating d.c., and that the synch pulses drive the beam current in the picture tube to cut-off. This is accomplished by the d-c restorer circuit.

SYNCH CIRCUITS

As mentioned previously the output of the video amplifier divides into two paths. We have just completed a discussion of the action along the first path. The second path which we will now discuss is concerned with the video and synch signal as it proceeds through a string of horizontal and vertical synch circuits.

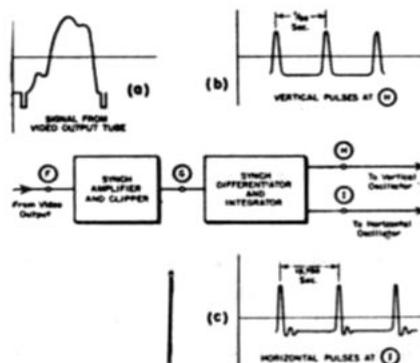

FIG. 25 SYNCH CIRCUIT WAVESHAPES

We again refer to Fig. 21 and observe that a portion of the video signal at F is fed into the synch section. Notice that the output of this section is fed into separate vertical and horizontal circuits at H and I.

We now refer to Fig. 25 for a more detailed explanation of this circuit.

Contained in this section we find a number of different types of circuits. The first is a synch amplifier. The second is a synch separator or clipper, the purpose of which is to reproduce the synch pulses in the output circuit and at the same time to attenuate all video picture components. Its effect can be compared to a peak voltage operating device.

The output of the synch separator is fed into a second amplifier which contains an integrator circuit for the passage of the vertical pulses and the attenuation of the horizontal; and a differentiator for the passage of the horizontal pulses and the attenuation of the vertical.

Now, we have assumed a certain sequence of circuits in our explanation which is not necessarily followed in all receivers. However, for purposes of explanation we have chosen this particular sequence with the understanding that of course some variations from it do exist.

Referring again to Fig. 25 again we notice that at F the signal input shown in (a) contains synch pulses and video picture energy. As explained previously, the video picture component is removed by the clipper. This action combined with the action of the integrating circuit results in a pure vertical pulse appearing at H. Likewise, the clipper action combined with the action of the differentiating circuit results in a pure horizontal pulse appearing at I. These pulses are shown in wave-shapes (b) and (c) respectively.

We are now ready to trigger the oscillators which are located in the next section. Referring again to Fig. 21 it can be seen that the output of the vertical integrating circuit at H feeds into the vertical oscillator and output section. The output of this section, shown at J, in turn feeds into the vertical deflecting coils of the picture tube.

We can now refer to Fig. 26. Here we have a more detailed view of the vertical sweep section. The action that takes place here begins with the signal pulse which

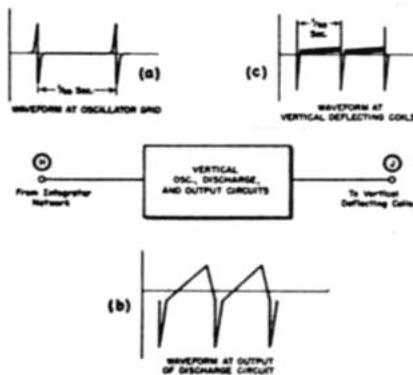

FIG. 26 VERTICAL SYNCH WAVEFORMS

triggers or discharges the vertical oscillator which operates at a frequency approximately equal to that of the incoming pulse. The latter makes this frequency exact with respect to the station being received. The output of the oscillator is fed into a suitable RC discharge circuit which develops the correct waveform re-

quired at this point. This signal is then fed into an output tube, the plate circuit of which is connected to the primary of a step-down transformer. The secondary of this transformer connects across the vertical deflecting coils of the picture tube.

DEFLECTING COIL WAVEFORM

At this point it must be remembered that in an electromagnetically deflected cathode ray tube the electron stream is deflected by the current in the coil. Thus, a saw-tooth current waveform in a deflecting coil will result in a linear sweep of the beam.

Referring again to Fig. 26, notice the different types of waveshapes that are developed in this section. In waveshape (b) which appears at the output of the discharge circuit we have a combination wave produced by the saw-tooth action of a condenser and the instantaneous action of a resistor. This type of wave is necessary in order to produce the voltage waveshape (c) across the vertical deflecting coils. It is in this manner that the effects of both resistance and inductance are taken into consideration in producing the required saw-tooth current wave through the coils.

We are now ready to proceed into the next section, which is the horizontal sweep unit. Again we refer to Fig. 21 in order to identify its position in the over-all layout of the receiver. Notice that the output of the horizontal differentiator circuit feeds into the horizontal sweep section at point I.

Referring now to Fig. 27 we notice that this section contains circuits which are almost identical with those found in the vertical sweep section. The first point of similarity is the oscillator. The incoming horizontal pulses trigger this oscillator to the exact frequency of the station being received. The output of the

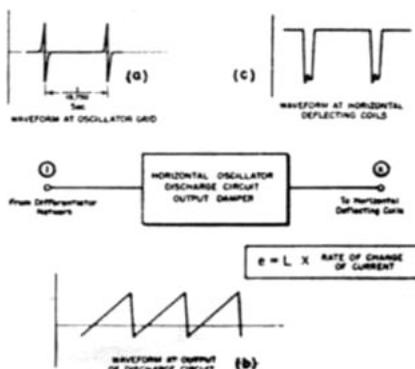

FIG. 27 HORIZONTAL SYNC WAVEFORMS

oscillator is then fed into a horizontal discharge circuit where the proper waveshape of the signal is developed. This wave is then fed into a horizontal output tube. Connected between this tube and the horizontal deflecting coils we find, as in the vertical circuit, an impedance matching transformer which transfers the energy from the plate circuit of the horizontal output tube to the horizontal deflecting coils of the picture tube.

In this figure we discover an additional circuit which is not present in the vertical section. This circuit, called a damper, contains a rectifier tube, the purpose of which is to damp out the high-frequency, high-voltage transients that are induced in the secondary winding of the horizontal transformer during a portion of the retrace period.

Remember that the horizontal trace frequency is pretty high--15,750 cycles per second; but the retrace frequency is much higher--around 75,000 cycles per second. For this reason the order of magnitude of the voltages induced is pretty high, in the order of many thousand volts. During a portion of this retrace period the horizontal damper tube is conductive and prevents these transients from disrupting the sweep cycle. Notice the wave shapes that appear in this section. Waveshape (a) is the pulse that is injected into the horizontal oscillator. Waveshape (b) is the combination wave produced at the output of the discharge tube. Waveshape (c) is the flattop voltage wave appearing across the horizontal deflecting coils. Remember that a flattop voltage wave produces a sawtooth current wave in a circuit which is predominantly inductive.

To those who might be a little puzzled at the reason for this statement we refer to the formula shown at the right side of the illustration. This formula states that the induced voltage across an inductor is proportional to the inductance in henrys and the rate of change of current in the coil. If the voltage remains constant, and the inductance is constant, this rate of change of current also remains constant. A current in which the rate of change is constant is linear and therefore a sawtooth.

The following paragraphs will deal with the practical methods that may be employed in order to observe the waveforms just discussed.

In order to become familiar with the general procedures of these tests it is best to tune in a station pattern under normal operating conditions. A pattern of this type results in a constant video signal and lends itself readily to easy interpretation.

INITIAL TEST POINT

The most convenient initial point of measurement is the output of the second detector. The reason for this choice is that the signal voltage at this point is 1

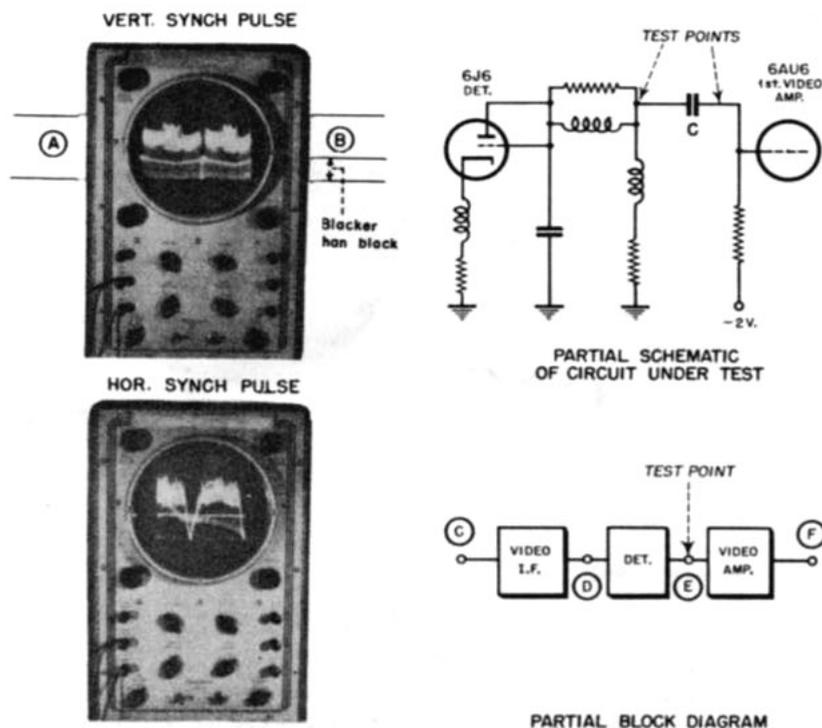

FIG. 28 WAVEFORMS, HORIZONTAL AND VERTICAL OBTAINED AT DETECTOR OUTPUT

or 2 volts, and lends itself to good observations on an oscilloscope. Remember that we are primarily concerned with measuring and observing the video picture signal and the synch pulses, and that these are first observable in their demodulated forms at the output of the second detector.

Fig. 28 at bottom of previous page illustrates a combined video signal and vertical synch pulse obtained at the detector output. The sweep frequency of the CRO has been set at 30 cycles in order to permit two of these pulses to appear on the screen. The partial circuit diagram on the left illustrates the test points for this test. This corresponds to point E on the block diagram. See Fig. 21.

To make this test a connection is made between the detector output and the vertical input connection on the CRO. Another connection is then made between the ground connections of the receiver and the oscilloscope. The detector output connection may be taken off at either side of the coupling condenser, C, whichever is most convenient. The receiver output is adjusted to its optimum level, thereby requiring a minimum setting of the vertical gain control on the scope. This will result in more accurate and satisfactory patterns.

Notice the amplitude A of the combined synch pulse and signal as compared with the signal amplitude itself shown as B. The middle line at B, represents the blanking level, and the height above this level--(in the slide this occurs below the blanking level because of the reversed phase of the pattern)--is the region called "blacker-than-black."

The blanking level should be 75% of the total height, A, according to FCC standards.

Shown in the lower right hand side of this illustration are the horizontal synch pulses and the associate picture signal. The same test point is used. However, the sweep frequency of the CRO is now adjusted to one-half the incoming horizontal synch pulse frequency. This is 15,750 divided by 2, or 7,875 cycles.

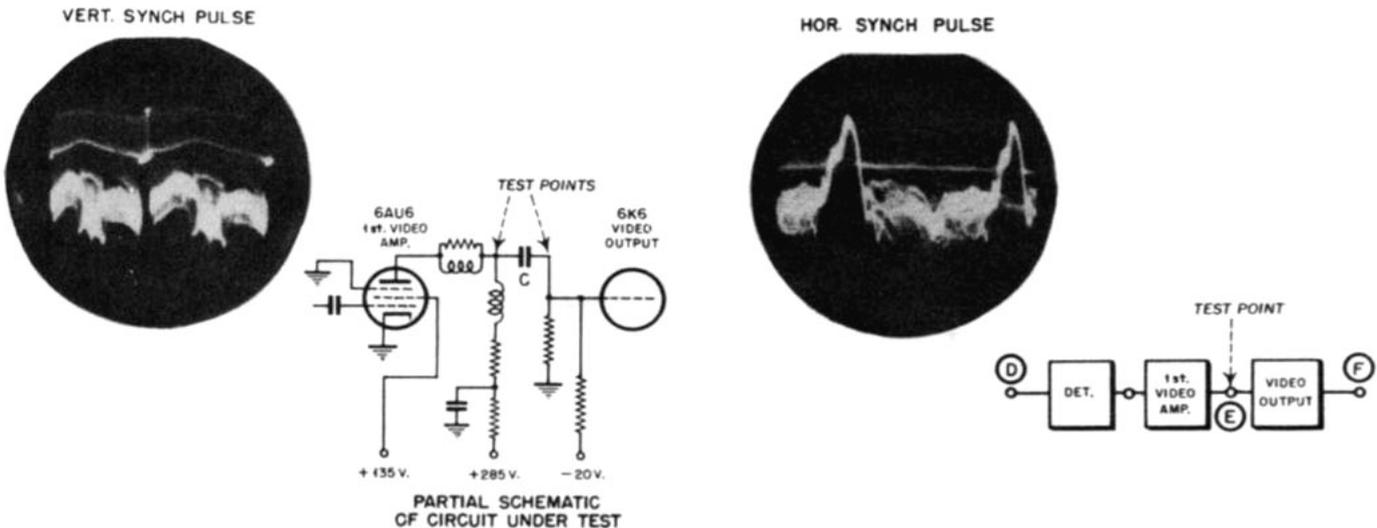

FIG. 29 HORIZONTAL AND VERTICAL PULSES OBTAINED AT 1ST VIDEO AMPLIFIER

Figure 29 shows the vertical and horizontal pulses at the output of the first video amplifier. Notice that the phase has been reversed 180° which is characteristic of vacuum tube action. The amplitude of the signal at this point is about 16 volts. Varying the gain of the receiver by means of the contrast control will produce corresponding variations in the height of the pattern.

As in the previous test, the sweep of the CRO is adjusted to portray two pulses. The test point may be made on either side of the coupling condenser, C, shown in the partial schematic at the left of the slide. The probe connection of the scope may be brought to the plate side of the coupling condenser if an isolating condenser is located in series with the vertical input terminal; and it usually is.

Proceeding now to the output of the final video stage, as shown in Fig. 30, we

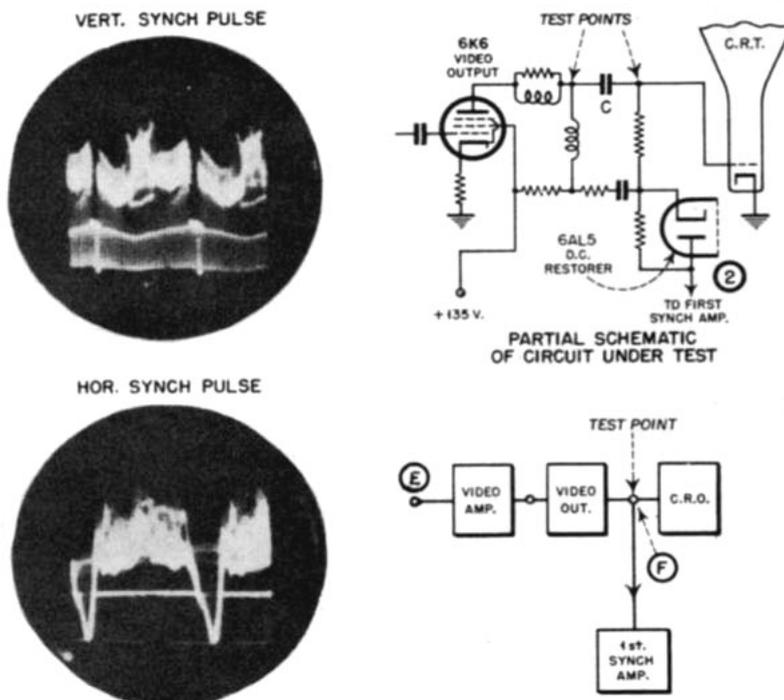

FIG. 30 HORIZONTAL AND VERTICAL PULSES OBTAINED AT VIDEO OUTPUT TUBE

notice that the phase for both horizontal and vertical plates is again reversed, and that the amplitudes of the signal are considerably increased. In this case it is 45 volts. This output is fed directly into the grid of the CRT, and as previously pointed out, represents a positive picture phase.

SYNCH CIRCUIT SECTION

A portion of the video signal is taken off the d-c restorer at the 6AL5 plate connection No. 2. The signal at this point, containing both video and synch components, with the video somewhat reduced, is fed into the first synch amplifier at a negative synch phase, or what amounts to the same thing, a positive picture phase.

This is shown in Fig. 31. The operating characteristics of this circuit result in a reduction of pulses due to noise and other interfering signals. The amplitude of the signal at the grid of the first synch amplifier is about one-fourth that of the output at the plate of the final video amplifier. This is due to the signal being taken off a point on a voltage divider connected across this circuit.

Fig. 32 shows the horizontal and vertical pulses as they appear at the grid of the synch clipper or separator. Notice that the amplitude at this point is 60 volts, and that the signal still contains considerable picture components. Also, the signal now has a negative picture phase, or a positive synch phase.

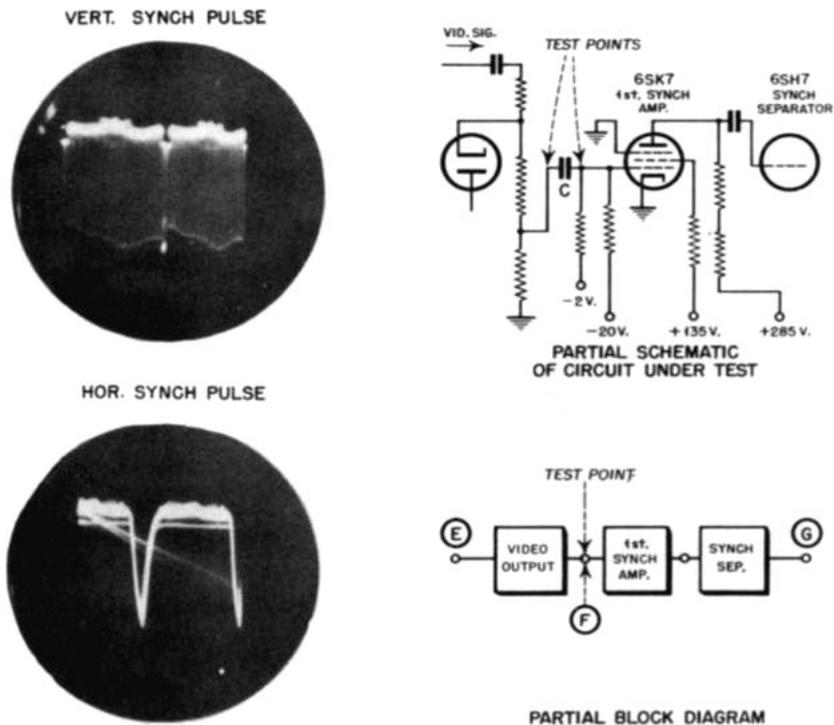

FIG. 31 PULSES OBTAINED AT 1ST SYNCH AMPLIFIER ON EITHER SIDE OF C

We now shift our take-off point to the output circuit of this tube, as shown in Fig. 33. Observe that the picture signal has now been completely eliminated, and that only the synch pulses remain. The amplitude of these pulses at this point is 80 volts, and the synch phase is now negative.

The action in this circuit that produces this clipping of the picture signal results from the following:

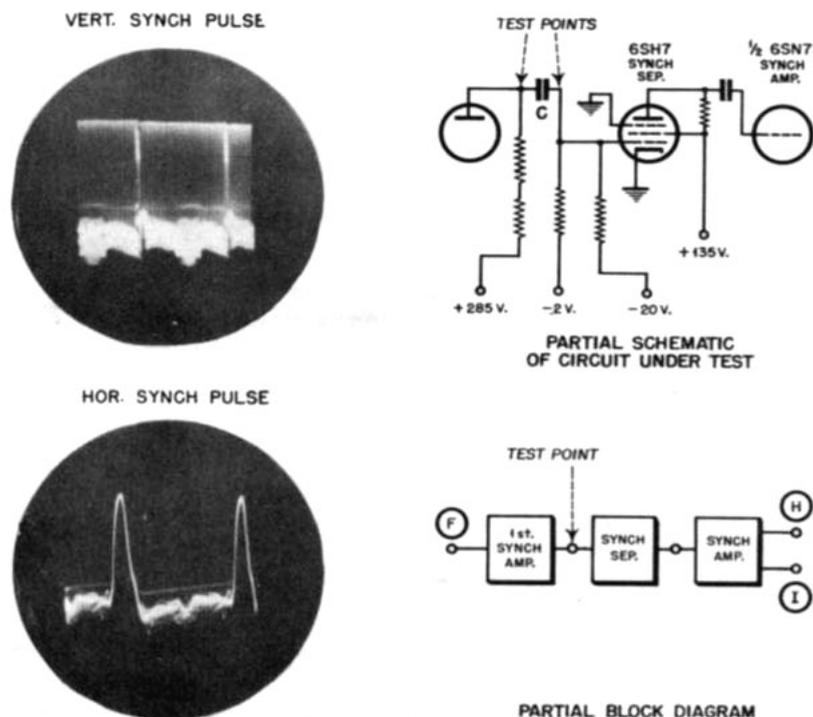

FIG. 32 PULSES OBTAINED AT INPUT OF 6SH7 SYNCH SEPARATOR. NOTE WAVEFORMS

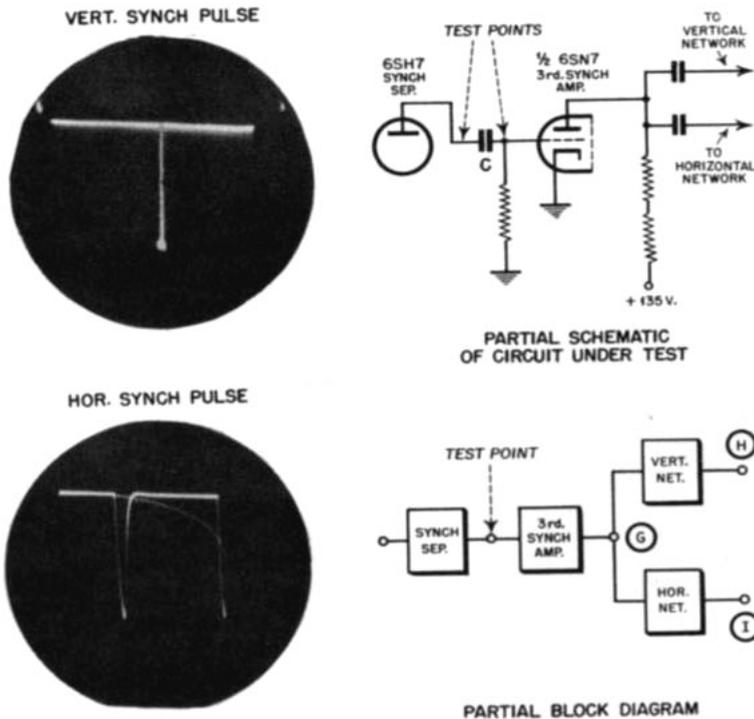

FIG. 33 HORIZONTAL AND VERTICAL PULSES OBTAINED AT 3RD SYNCH AMP. INPUT

1. The picture signal at the grid of the tube has a negative polarity.

2. The operating voltages on the tube are such that all negative portions of the signal are cut off.

Since the polarity of the video or picture portion of the signal is negative, and since all negative portions of the signal are clipped off, only the synch pulses remain.

The next test point is the plate of the third synch amplifier. The polarity of the synch signal at the grid of this tube is now negative. At the plate it becomes positive. The complete change taking place in the synch signal polarity in the three stages of the synch amplifiers is shown in Fig. 34. Here we see a negative synch pulse entering the grid of the first synch amplifier, and, after going through three complete 180° phase reversals, emerging from the last stage with a positive polarity.

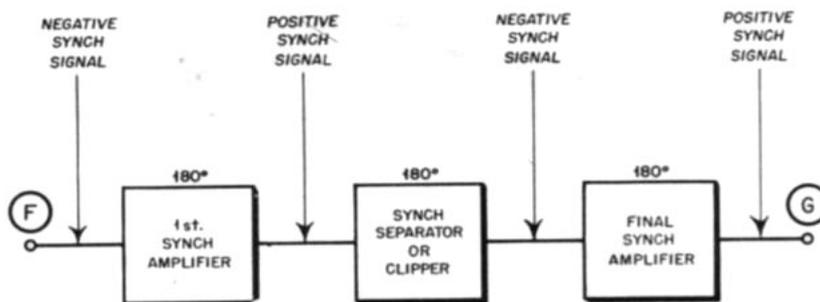

SYNCH SIGNAL PHASE REVERSALS IN SYNCH AMPLIFIER SECTION

FIG. 34 SIGNAL PHASE IS REVERSED 180° AS IT PASSES THROUGH EACH TUBE

This last synch tube, which is one half of a duo-triode, operates at low enough potentials so that an 80 volt signal applied to the grid drives the tube beyond cut-off passing only the peaks of the signal. This results in an additional clipping action, thereby further reducing noise and other interfering pulses.

INTEGRATING CIRCUIT

The amplitude at the output of this tube, which is shown as point 1 in Fig. 35

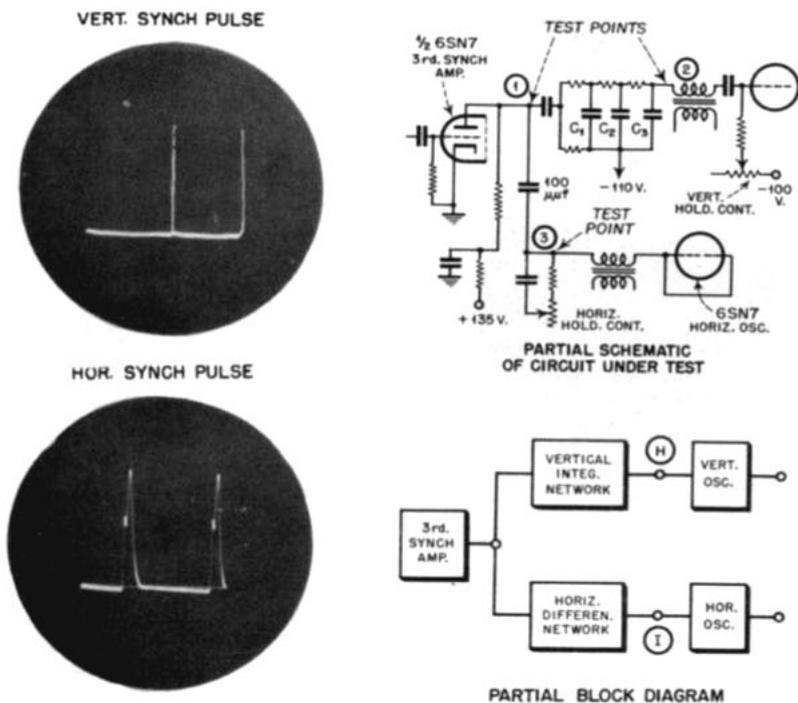

FIG. 35 WAVEFORMS OBTAINED AT HORIZONTAL AND VERTICAL SEPARATION POINTS

is 30 volts. The synch pulse phase is positive, and we are now in a position to inject this signal into the horizontal and vertical blocking oscillators for purposes of triggering them to the exact frequency of the incoming station pulses.

The signal at the output of the final synch amplifier contains both the horizontal and vertical pulses which we must separate from each other. This is done by the integrating and differentiating networks. These are shown more clearly in Fig. 35 as combination R-C filter circuits. The integrating circuit shown at the top left consists of a number of resistors and capacitors connected in such a manner as to short out the horizontal pulses and build up the amplitude of the vertical pulses. Notice the shunt capacitors, C_1 , C_2 , and C_3 . These condensers in addition to building up the amplitude of the vertical synch signal during successive pulses of the serrated vertical synch pulse, short out the higher frequency horizontal pulses, leaving only the vertical pulse to reach the grid of the 6J5 vertical oscillator.

Proceeding now to the differentiating circuit, the 100 mmf condenser connecting the output of the third synch amplifier to the input of the horizontal oscillator presents a high reactance to the low frequency vertical pulses as compared to high frequency horizontal pulses, so that the signal permitted to pass thru this condenser contains only the horizontal pulses.

If we apply the test probe of the CRO to point 1, both the vertical and the horizontal pulses appear. At point 2 only the vertical pulses appear, and at point 3 only the horizontal pulses appear.

We are now ready to trace the vertical pulses as they proceed from the output of the 6J5 oscillator to the input of the vertical deflecting coils. The lower left-hand portion of Fig. 36 is devoted to the block diagram of this portion of the circuit.

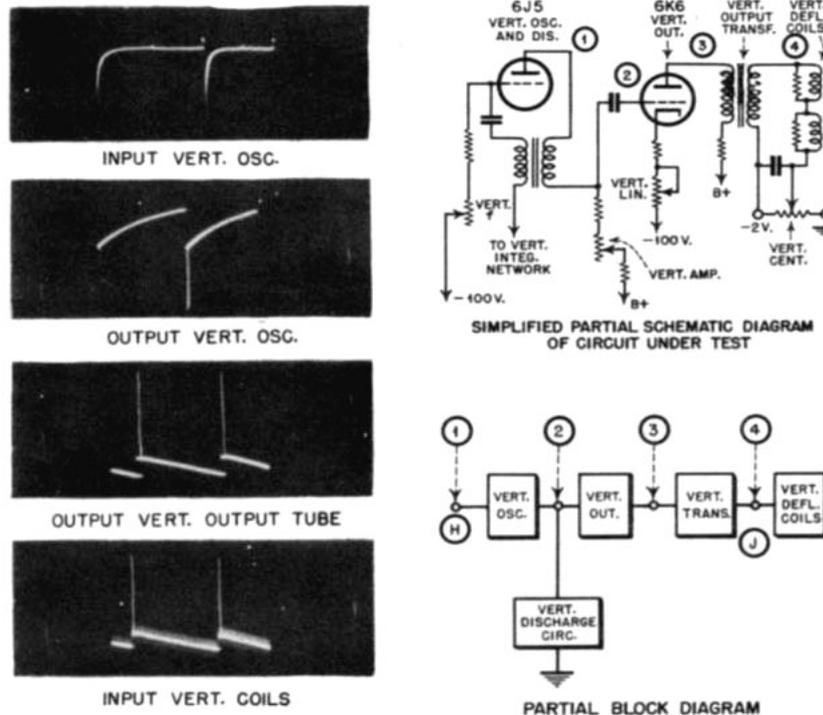

FIG. 36 WAVEFORMS OBTAINED AT VARIOUS TEST POINTS IN VERTICAL CIRCUIT

The upper left-hand portion of the figure is confined to a simplified partial schematic of this circuit. The four test points shown in the block diagram are indicated in the partial schematic by identical numbers. Thus:

No. 1 is the input of the vertical oscillator.

No. 2 is the output of the vertical oscillator, the amplitude of which is about 120 volts. This signal is acted upon by the discharge or peaking circuit. The object of this circuit is to obtain a wave at the output of the oscillator which insures the presence of a sawtooth current wave in the vertical deflecting coils. But, more on that shortly.

No. 3 is the output of the vertical deflecting coils. The potential at this point is about 65 volts.

No. 4 is the input to the vertical output tube, which is about 450 volts.

The corresponding waveforms for test points 1, 2, 3, and 4 are shown at the right of the screen.

No. 1 proceeding from top to bottom indicates the sharp steep discharge, and slow saw-tooth charge portions of the wave which are characteristic of the blocking oscillator.

No. 2 indicates the effect of the peaking, or discharge circuit on this waveform. Variations of this waveform may be produced by varying the vertical amplitude control. This is an excellent check on the operation of this circuit.

No. 3 indicates the waveform of the pulse at the plate of the vertical output tube, or the 6K6. Notice how high the pulse voltage is for the retrace portion. This is necessary to insure a high retrace current rate on the vertical deflecting coils during the retrace period.

PEAKING

The reader will recall, the formula relating to voltage, inductance, and the rate of change of current in a coil. This formula is repeated again in two forms:

$$e = L \times \text{Rate of change of current}$$

$$\text{Rate of change of current} = e/L$$

During the retrace period the frequency is much higher than the 60 cycle frequency of the trace period. As a result, the reactance set up by the inductance in the coil is much higher than before. This affects the current considerably. From the formula shown above, in order to get a high and fast discharge of current during the retrace period the voltage amplitude must be high and its waveform steep.

Returning again to Fig. 36, and examining waveform No. 4 once again, we notice that the trace portion of the voltage curve is somewhat of a sawtooth. This is due to the fact that during the trace period, the inductance of the vertical deflecting coil is negligible as compared to its resistance. In a resistance, if we want a saw-tooth current we must have a saw-tooth voltage. This explains why, in the composite wave, the waveform of the retrace is a sharp high amplitude pulse, and the waveform of the trace is a low amplitude saw-tooth.

HORIZONTAL CIRCUIT

We can now proceed to the horizontal oscillator and the circuits devoted to the development of the horizontal sweep. Fig. 37 illustrates the partial schematic

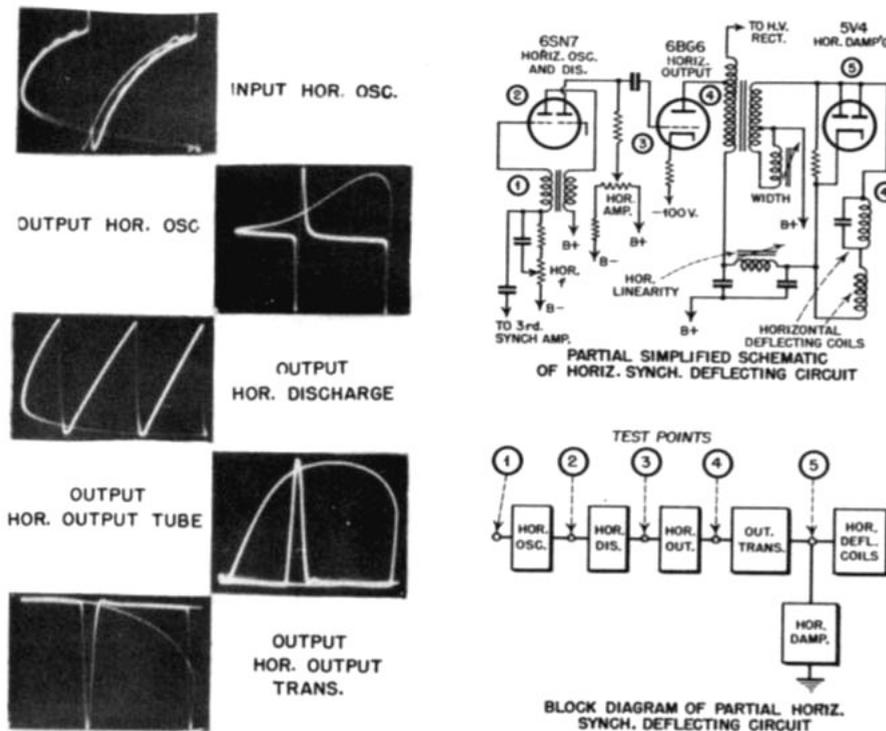

FIG. 37 WAVEFORMS OBTAINED AT VARIOUS POINTS IN HORIZONTAL SWEEP CIRCUIT

of this portion of the circuit in the upper left portion of the screen. Below it is the block diagram showing the test points numbered to correspond to the same points in the schematic above. These test points are as follows:

No. 1 is the input of the horizontal oscillator.

No. 2 is the output of the horizontal oscillator, at about 120 volts.

No. 3 is the output of the horizontal discharge circuit, at about 45 volts.

No. 4 is the output of the horizontal output tube, at about 4,000 volts. The utmost caution should be used when measuring high voltages of this nature.

No. 5 is the output of the horizontal output transformer, which is about 800 volts, and represents the voltage waveform appearing across the horizontal deflecting coils. Notice the flattop characteristic of this waveform. It will be recalled that in order to obtain a sawtooth current wave in a circuit which is predominantly inductive, a flattop voltage wave is required. When measuring these high voltages a high voltage test probe should be used, and a capacitance voltage divider should be employed for the CRO to prevent damage to its input circuit.

CAPACITY VOLTAGE DIVIDER FOR OBSERVING HORIZONTAL SWEEP CIRCUIT PULSE WAVEFORMS

The protective device mentioned above in Mr. Marshall's article should be used in conjunction with the oscilloscope section of the GENESCOPE for checking high voltage circuits. The maximum stress for which the oscilloscope input is designed is 500 volts. A capacity voltage divider can be constructed as follows:

Connect two capacitors in series as shown in figure 38A. The horizontal sweep pulse waveform voltage will divide across the two capacitors in inverse ratio to their capacities. The peak-to-peak voltage in the pulse may be 4000 or more volts, and only a small fraction of this amount should appear across the oscilloscope input; this prevents damage to the oscilloscope and also preserves the original waveshape. Capacitor C1 needs to have a low capacity with a high voltage rating, while C2 needs a value 200 or 300 times as great. The voltage rating of C2 is not critical but should be 200 volts or more. Do not use an electrolytic, however.

To prevent loading in the horizontal sweep circuit, the impedance of the divider should be high. This can be done by keeping the value of C1 small. An inexpensive small capacitor with a high voltage rating utilizes a high voltage rectifier tube with its filament not lighted. The plate is used as one side of the capacitor and the filament as the

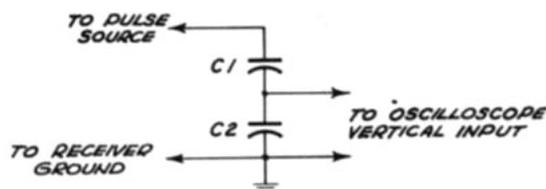

A. CAPACITY DIVIDER FOR HORIZONTAL SYNC PULSES

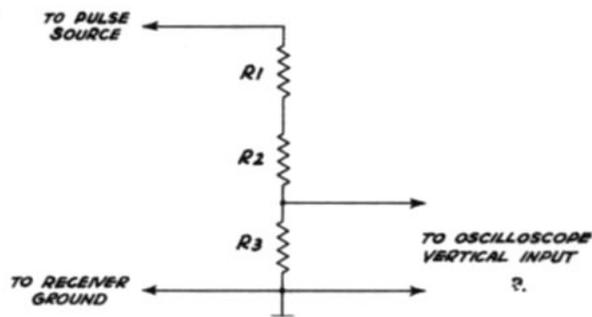

B. RESISTANCE DIVIDER FOR VERTICAL SYNC PULSES

FIG. 38. VOLTAGE DIVIDERS FOR USE WITH GENESCOPE

other. If a 1B3GT were used for C1, the capacity would be 1.5 uuf and it would withstand upwards of 30000 volts. If a 1X2 were used, the values would be 1 uuf and 15000 volts. Either tube will provide a high enough reactance at 15750 cycles to prevent any circuit loading when the divider is connected to any test point in the horizontal sweep circuits. The probe to be connected to the pulse source can be the plate cap lead with a clip on the probe end. Keep this lead short: eight inches should be long enough.

A ceramic, mica, or air dielectric capacitor from 200 to 400 uuf can be used for C2. Connect the clips at the end of the VERTICAL INPUT cable across C2.

Caution: Do not make the connections into the receiver when it is on. With the receiver off, connect the divider ground to the receiver ground and the "hot" probe to the source of pulse in the horizontal sweep circuit. Then turn the receiver on. Adjustments can then be made on the oscilloscope without any danger to the operator.

RESISTANCE DIVIDER FOR OBSERVING VERTICAL SWEEP CIRCUIT PULSE WAVEFORMS

When observing the waveforms in the vertical sweep circuits of a television receiver, a resistance divider will work best for the high voltage low frequency pulses. A suggested circuit for the resistance divider follows: connect three resistors in series as shown in figure 38b. Resistors R1 and R2 can be 10 megohms each and R3 can be 100K. Connect the clips at the end of the VERTICAL INPUT cable across R3. With the receiver OFF connect the "hot" probe to the source of pulse in the vertical sweep circuit. Then turn the receiver on. Adjust the oscilloscope to produce the waveforms shown in Figure 36.

MAINTENANCE

The Model 480 GENESCOPE is mounted to its case by 26 screws, 18 around the edge of the front panel and 4 on each side of the Oscilloscope section of the panel. Removing these 26 screws will allow the assembly to be removed from the case. Fig. 39 is a rear view of the GENESCOPE with its case and internal shielding removed. Nine of the sixteen tubes are available upon removing the unit from its case. This includes the 5Z4 rectifier, 2-6X4 rectifiers, 4-6J6 oscilloscope amplifiers, the 6J6 oscilloscope sweep and blanking tube and the 3KP1 Cathode Ray tube.

The FM Tuner unit and four additional tubes are available when the rear cover of the FM section is removed. This includes the 6AK5 FM oscillator, 6C4 fixed oscillator, 6AK5 mixer, and 6C4 blanking tube.

The AM Tuner, Crystal Calibrator, Audio Oscillator and three additional tubes are available by removing the rear cover of the AM section. The tubes in this section include the 6C4 AM oscillator, 6J6 Crystal Oscillator and Mixer and the 6C4 Audio Oscillator.

The tubes of the GENESCOPE should be checked occasionally in order to insure good performance. The Model 480 GENESCOPE is adjusted carefully at the factory by means of precision standards but due to the nature of Very High Frequency circuits, ageing of parts or replacement of tubes may require re-adjustment of the oscillator circuits in order to maintain original accuracy.

Adjust the GENESCOPE, when necessary, against its own crystal calibrator as follows:

1. Remove the GENESCOPE from its case and take off the back and top shields of both oscillator sections. Turn the POWER switch to OPERATE and allow the GENESCOPE to warm up for at least 15 minutes.

2. Set the **GENESCOPE** controls as specified in **CALIBRATION PROCEDURES**, page

3. Set the **A.M. GENERATOR RANGE** switch at **A**, **SIGNAL** switch to **CAL.**, and **SIGNAL ATTENUATORS** low, Tune the oscillator to the 7.5 mc. calibration check point.

4. Adjust **C9** until the 7.5 mc. zero beat indication occurs when the dial pointer indicates exactly 7.5 mc.

5. Tune the oscillator for the 3.75 mc. calibration check point. Adjust **L6** until the beat occurs when the dial pointer indicates exactly 3.75 mc. Recheck the 7.5 mc. setting and readjust **C9** if necessary.

6. Set the **A.M. GENERATOR RANGE** switch to **B**. Tune to the 35 mc. calibrating check point and adjust **C8** until the check point indication occurs when the dial pointer indicates exactly 35 mc.

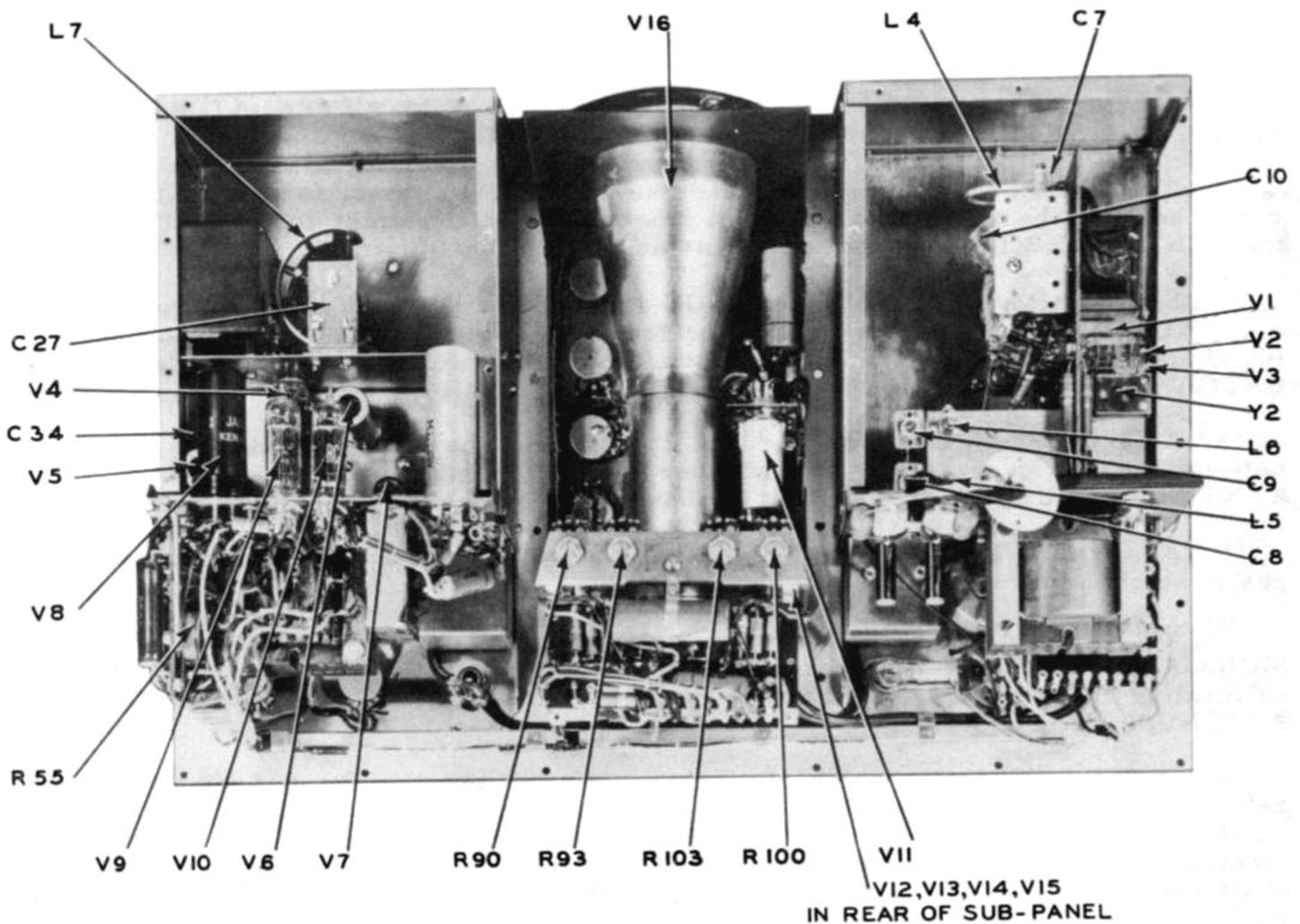

FIG. 39. REAR VIEW OF THE GENESCOPE CASE AND SHIELDING REMOVED

7. Tune to the 15 mc. calibration check point and adjust L5 until the pointer is over the 15 mc. mark on the dial. Recheck the 35 mc. tuning point.

8. Set the A.M. GENERATOR RANGE switch to band C. Tune to the 120 mc. calibration check point and adjust C7 until the zero beat indication occurs when the dial pointer indicates exactly 120 mc.

9. Tune to the 75 mc. calibrating check point. This should fall exactly at the dial pointer position for 75 mc. unless L4 has been moved physically. If necessary, loosen the two set screws holding L4 in place and shift L4 in or out to obtain the beat pattern at the 75 mc. dial indication. Recheck the 120 mc. point. Replace the top shield of the A. M. Generator if it was removed for alignment to this step.

10. Connect a crystal diode (such as a 1N34) between the center contacts of the OUTPUT and VERTICAL INPUT jacks.

11. Set the SIGNAL switch at CAL. Tune the A. M. Generator to its 170 mc. calibrating check point. Turn the SIGNAL switch to UNMOD. R.F. and set the SIGNAL ATTENUATORS to 10 and MAX.

12. Set the F.M. GENERATOR RANGE switch at B, F.M. ATTENUATORS to MAX. and 10, F.M. SWEEP to 0, PHASING to 0, and BLANKING to OFF.

13. Tune the F. M. Generator around the 170 mc. dial mark for a zero beat indication between the two generators. See whether the dial pointer indicates 170 mc. on the CENTER FREQUENCY dial or if it is above or below the mark.

14. Set the A.M. GENERATOR RANGE to B, SIGNAL switch to CAL., and SIGNAL ATTENUATOR potentiometer to 6. Tune the A. M. Generator to its 70 mc. calibrating check point. Turn the SIGNAL switch to UNMOD. R.F. and the SIGNAL ATTENUATOR potentiometer to 10.

15. Tune the F. M. Generator around the 140 mc. mark on the dial for a zero beat between the two generators. See whether the dial pointer indicates 140 mc. on the CENTER FREQUENCY dial, or if it is above or below the mark.

16. Adjust C27 for a compromise setting for the 170 mc. and the 140 mc. frequency positions of the pointer.

17. Set the A.M. GENERATOR RANGE switch to C, SIGNAL switch to CAL., and SIGNAL ATTENUATOR potentiometer to 6. Tune the A.M. Generator to the 240 mc. calibrating check point. Return the SIGNAL switch to UNMOD. R.F. and the SIGNAL ATTENUATOR potentiometer to 10.

18. Tune the F. M. Generator around the 240 mc. point on the dial for a zero beat between the two generators. Zero beat should occur at the 240 mc. mark on the dial unless the rotor for L7 has been moved on the tuning knob shaft. If it needs adjustment, tune to the zero beat point for 240 mc., loosen the allen head set screw on the shaft coupler, turn the tuning knob to place the pointer over the 240 mc. dial mark while holding L7 in position, and then tighten the allen head set screw. Recheck the 170 mc. and 140 mc. indications.

19. Set the SIGNAL switch at CAL. and the SIGNAL ATTENUATOR potentiometer to 6. Tune the A. M. Generator to the 165 mc. check point. Return the SIGNAL switch to UNMOD. R.F. and the SIGNAL ATTENUATOR potentiometer to 10.

20. Tune the F. M. Generator around the 165 mc. mark on the dial for a zero beat indication on the oscilloscope.

21. Remove the crystal diode from the OUTPUT and VERTICAL INPUT jacks. Attach the cables to these jacks.

22. Connect the OUTPUT cable to the input of an i-f strip tuned for a response pattern in the vicinity of 20 to 25 mc. Connect the VERTICAL INPUT cable to the grid or plate of the last i-f amplifier to obtain a wave form similar to figure 18B when the intermediate frequency is tuned with the F. M. Generator.

23. Set the A.M. GENERATOR RANGE switch at B, SIGNAL switch to CAL., and SIGNAL ATTENUATORS to 0 and X1. Tune the A.M. Generator to the 25 mc. calibrating check point. Set the SIGNAL switch at UNMOD. R.F.

24. Set the F.M. GENERATOR RANGE switch at A, F.M. ATTENUATORS at MAX. and 10, and F. M. SWEEP at 10. Tune C34 until the maximum i-f response is seen on the oscilloscope. Note that several response curves can be seen with very little rotation of C34. Tune to the largest response.

25. Advance the SIGNAL ATTENUATORS until a marker can be seen on the response pattern. Keep them set as low as possible with the marker just visible.

26. Reduce the F. M. SWEEP gradually toward zero. Adjust C34 to keep the marker on the trace as long as possible while reducing the sweep control. This is a rough adjustment of C34.

27. Remove the OUTPUT and VERTICAL INPUT cables and replace the 1N34 between the center jack contacts. Turn the SIGNAL switch to CAL. and the SIGNAL ATTENUATOR potentiometer to 6. Set the A. M. GENERATOR RANGE switch to C and tune the A. M. Generator to the 170 mc. check point. Turn the SIGNAL switch to UNMOD. R.F. and the SIGNAL ATTENUATOR potentiometer to 10.

28. Set the F. M. GENERATOR RANGE switch to B and F. M. SWEEP at 0. Tune the F. M. Generator for a zero beat indication at 170 mc.

29. Set the SIGNAL ATTENUATOR potentiometer at 6, the SIGNAL switch at CAL., and the A. M. GENERATOR RANGE switch at B. Tune the A. M. Generator to the 30 mc. calibrating check point. Set the SIGNAL switch at UNMOD. R.F. and the SIGNAL ATTENUATOR potentiometer to 10.

30. Set the F. M. GENERATOR RANGE switch at A. Very carefully adjust C34 for a zero beat indication. This is a fine adjustment and should require only a slight touch-up adjustment on C34.

Caution: this fine setting should require less than 3° of rotation of C34. If it appears to need more, go back to step 19 and repeat the steps more carefully.

31. Set the SIGNAL switch at CAL. and the SIGNAL ATTENUATOR potentiometer at 6. Tune the A. M. Generator to the 35 mc. calibrating check point. Turn the SIGNAL switch to UNMOD. R.F. and the SIGNAL ATTENUATORS to 10 and MAX.

32. Observe the oscilloscope while rotating the F. M. tuning knob. A constant zero beat should occur between the 35 mc. from the A. M. Generator and 140 mc. from the fixed oscillator regardless of the position of the pointer on the CENTER FREQUENCY dial. If this situation does not exist, the fixed oscillator is tuned to an incorrect frequency. Go back to step 19 and repeat the 140 mc. oscillator adjustment.

3. Remove the crystal diode and replace all shielding. The GENESCOPE oscillators are now aligned within the close tolerances to which they were adjusted when it was manufactured.

SWEEP ADJUSTMENT

The f-m sweep motor is factory adjusted to provide a sweep bandwidth of 15 mc. when operated on 110 volts, 60 cycles, and with the F. M. Generator tuned to 160 mc. and the F. M. SWEEP control at 10. Operation on other line voltages or at line frequencies other than 60 cycles will require resetting of the sweep limiter adjustment, R55. Use the following procedure to adjust R55.

1. Turn the POWER switch of the GENESCOPE to OPERATE and allow 15 minutes for the unit to warm up. Set the FUNCTION switch of the oscilloscope to 60 \sim SWEEP. Connect a crystal diode (such as a 1N34) between the center contacts of the OUTPUT and VERTICAL INPUT jacks.

2. Set the A. M. GENERATOR RANGE switch to C. SIGNAL switch to CAL., and SIGNAL ATTENUATORS to 6 and MAX. Tune the A.M. Generator to the 160 mc. check point. Turn the SIGNAL switch to UNMOD. R.F. and the SIGNAL ATTENUATOR potentiometer to 10.

3. Set the F. M. GENERATOR RANGE switch to B, F. M. ATTENUATORS to MAX. and 10. and F. M. SWEEP to 0. Tune the F. M. Generator to zero beat at 160 mc.

4. Turn the F. M. SWEEP to 10 and the PHASING control to a position which produces an open oval or circle on the oscilloscope. Note the two markers on the pattern. Reduce the SIGNAL ATTENUATORS to as low a setting as will still keep the markers visible.

5. Rotate the A. M. Generator tuning knob and note that the two markers move around the trace until they join, produce a zero beat, and then disappear. Read the frequency on the A. M. Generator dial at the point where the markers zero beat.

6. Rotate the A. M. Generator tuning knob in the opposite direction until the markers move to the opposite side of the trace and join and zero beat again. Read the frequency on the A. M. Generator dial again at this zero beat point.

7. The frequencies in steps 5 and 6 identify the limit frequencies toward which the F. M. Generator is being swept. These should have a difference of 15 mc. If they do not, adjust R55 to correct.

CAUTION: Do not adjust the sweep beyond the 15 mc. bandwidth point. The motor reaches the limit of its swing a little beyond this point and will be damaged if it is allowed to strike the stops for any considerable period of time.

OSCILLOSCOPE TUBE

An adjustment is provided at the base of the 3KP1 tube socket so that the tube may be rotated to set the horizontal trace parallel with the mirror opening. To rotate the tube loosen the two screws on the lower side of the tube socket flange and rotate the tube to the desired position. Retighten screws. To remove the tube, insert a screwdriver between the tube base and socket and pry it out of the socket. Lift the tube up through the shield. **DO NOT ATTEMPT TO PULL THE TUBE OUT OF ITS SOCKET FROM THE TOP.**

The Oscilloscope mirror tension may be adjusted by tightening or loosening the two screws on top of the cabinet directly behind the mirror. The Oscilloscope mirror should

be cleaned with soap and water then polished with tissue paper or treated tissues ordinarily used for cleaning eye glasses. DO NOT USE ABRASIVE POLISHES OF ANY KIND.

If any tube in either the vertical or the horizontal amplifier is changed, the voltage at the first anode and the d-c voltage applied to each deflection plate should be rebalanced. Use the following procedure;

1. Turn POWER switch to OPERATE.
2. Set the VERTICAL CENTERING and HORIZ. CENTERING controls at mid rotation (straight up).
3. With a 20000 ohm-per-volt voltmeter, measure the voltage at pin 7 of the cathode ray tube (white lead with red tracer). This should be about 200 volts dc.
4. Adjust resistors R90, R92, R100, and R103 for the reference voltage (step 3) at terminals 11, 12, 14, and 15 on the direct input terminal board. If the voltages will not all balance at the reference voltage, make these four voltages identical with each other at a value as close to the reference as possible. Adjust R103 first and measure the voltage at terminal 11; then measure at terminal 12 and adjust R100. Recheck terminal 11 because there is interaction between these adjustments. Follow the same procedure at terminal 14 with R90, then terminal 15 with R92.
5. Adjust the INTENSITY and FOCUS control and observe the spot on the face of the cathode ray tube. It should be centered vertically and horizontally and have a well defined and focussed appearance.

Aged tubes are used in the vertical and horizontal amplifier circuits. When replacing any of the 6J6 tubes, age the new tube with 10 volts across its filament for 30 minutes to assist in stabilizing the circuit operation and matching the characteristics of the other tubes in the circuits.

Should your GENESCOPE fail to give satisfactory service due to repairable damage, it can be returned to the factory for repairs. Always accompany any equipment sent in for repair with a statement indicating where the trouble is; for example, "A. M. Generator dial binds" or "oscilloscope intermittent after 2 hours of use", etc. This will facilitate repairs, keep your bill to a minimum, and insure that the fault will be corrected when you receive your GENESCOPE again.

WARRANTY

SIMPSON ELECTRIC COMPANY warrants each instrument and other articles of equipment manufactured by it to be free from defects in material and workmanship under normal use and service, its obligation under this warranty being limited to making good at its factory any instrument or other article of equipment which shall within 90 days after delivery of such instrument or other article of equipment to the original purchaser be returned intact to it, or to one of its authorized service stations, with transportation charges prepaid, and which its examination shall disclose to its satisfaction to have been thus defective; this warranty being expressly in lieu of all other warranties expressed or implied and of all other obligations or liabilities on its part and SIMPSON ELECTRIC COMPANY neither assumes nor authorizes any other persons to assume for it any other liability in connection with the sale of its products.

This warranty shall not apply to any instrument or other article of equipment which shall have been repaired or altered outside the SIMPSON ELECTRIC COMPANY factory or authorized service stations nor which has been subject to misuse, negligence or accident, incorrect wiring by others, or installation or use not in accord with instructions furnished by the manufacturer.

**PARTS LIST FOR
MODEL 480 GENESCOPE**

Circuit Reference	Description	Simpson Part
C1	Capacitor, 8200 uuf mica	1-113911
C2	Capacitor, .05 uf 400v. paper	1-113899
C3	Capacitor, 8200 uuf mica	1-113911
C4	Capacitor, .05 uf 400v. paper	1-113899
C5	Capacitor, 5000 uuf ceramic	1-113913
C6	Capacitor, .02 uf 400v. paper	1-113898
C7	Capacitor, 4.5-25 uuf trimmer	1-113914
C8	Capacitor, 2.2-20 uuf trimmer	1-113891
C9	Capacitor, 2.2-20 uuf trimmer	1-113891
C10	Capacitor, 2 gang tuning	1-113916
C11	Capacitor, 2000 uuf ceramic	1-113855
C12	Capacitor, 2000 uuf ceramic	1-113855
C13	Capacitor, 10 uuf ceramic	1-113895
C14	Capacitor, 470 uuf ceramic	1-113978
C15	Capacitor, 2000 uuf ceramic	1-113855
C16	Capacitor, 0.1 uf 400v. paper	1-113902
C17	Capacitor, 2000 uuf ceramic	1-113855
C18	Capacitor, 2000 uuf ceramic	1-113855
C19-26	Capacitors, 1000 uuf feedthrough	1-114643
C19-26	Assembled on one plate	10-890126
C27	Capacitor, 2-6 uuf trimmer	1-113915
C28	Capacitor, 100 uuf ceramic	1-113912
C29	Capacitor, 220 uuf ceramic	1-113854
C30	Capacitor, 220 uuf ceramic	1-113854
C31	Capacitor, 220 uuf ceramic	1-113854
C32	Capacitor, 3.3 uuf ceramic	1-113893
C33	Capacitor, 3.3 uuf ceramic	1-113893
C34	Capacitor, 3.5-15 uuf trimmer	1-113920
C35	Capacitor, 100 uuf ceramic	1-113912
C36	Capacitor, 220 uuf ceramic	1-113854
C37	Capacitor, 220 uuf ceramic	1-113854
C38	Capacitor, 2000 uuf ceramic	1-113855
C39	Capacitor, 5000 uuf ceramic	1-113913
C40	Capacitor, 5000 uuf ceramic	1-113913
C41	Capacitor, 220 uuf ceramic	1-113854
C42-50	Capacitors, 1000 uuf feedthrough	1-114643
C42-50	Assembled on one plate	10-890127
C51	Capacitor, 470 uuf ceramic	1-113978
C52	Capacitor, 470 uuf ceramic	1-113978
C53	Capacitor, 0.25 uf 400v. paper	1-113903
C54	Capacitor, 40-10uf 350V.D.C. Electrolytic	1-113963
C55	Capacitor, 10 uf 450 V.D.C. Electrolytic	1-113964
C56	Capacitor, 10-10-10uf 450 V.D.C. "	1-113962
C57	Capacitor, .05 uf 400v. paper	1-113899
C58	Capacitor, .02 uf 400v. paper	1-113898
C59	Capacitor, .02 uf 400 v. paper	1-113898
C61	Capacitor, .01 uf 400v.paper	1-113896
C63	Capacitor, 0.1 uf, 400v. paper	1-113902
C64	Capacitor, 2-12 uuf trimmer	1-113892
C65	Capacitor, 150 uuf ceramic	1-113907
C66	Capacitor, 2 uf 200v. paper	1-113905

Circuit Reference	Description	Simpson Part Number
C67	Capacitor, 120 uuf ceramic	1-113906
C68	Capacitor, 680 uuf ceramic	1-113908
C69	Capacitor, 3900 uuf ceramic	1-113909
C70	Capacitor, .02 uf paper	1-113898
C71	Capacitor, 0.1 uf paper	1-113902
C72	Capacitor, 0.5 uf 200v. paper	1-113904
C73	Capacitor, 3300 uuf mica	1-113910
C74	Capacitor, 3300 uuf mica	1-113910
C75	Capacitor, 0.25 uf 400v. paper	1-113903
C76	Capacitor, 0.25 uf 400v. paper	1-113903
F1	Fuse 2 amp 3AG	1-112911
J1	Jack, OUTPUT	1-113982
J2	Jack, VERT. INPUT	1-113983
J3	Jack, HORIZ. INPUT	1-113983
L1	Line filter	10-890040
L2	Line filter	10-890040
L3	85 uh choke coil	10-890034
L4	Oscillator coil, A.M. Band "C"	10-890033
L5	Oscillator coil, A.M. Band "A"	10-890031
L6	Oscillator coil, A.M. Band "B"	10-890032
L7	Coil assembly, F. M. tuner	10-890028
L8	Oscillator coil, 140 mc.	10-890030
L9	Filter choke, power supply	10-890039
L10	20 mh peaking coil	10-890035
L11	20 mh peaking coil	10-890035
M1	Sweep motor assembly	22-302118
R1	Resistor, 56k 1/2w. 10%	1-113947
R2	Resistor, 33k 1/2w. 10%	1-113933
R3	Resistor, 22k 2 w. 10%	1-113959
R4	Resistor, 100k 1/2w. 10%	1-113949
R5	Resistor, 100k 1/2w. 10%	1-113949
R6	Resistor, 1k 1/2w. 10%	1-111689
R7	Resistor, 47 ohms 1/2w. 10%	1-113921
R8	Resistor, 100k 1/2w. 10%	1-113949
R9	Resistor, 6.8k 1/2w. 10%	1-113048
R10	Resistor, 22k 2 w. 10%	1-113959
R11	Resistor, 22k 2w. 10%	1-113959
R12	Resistor, 18k 1/2w. 10%	1-113943
R13	Resistor, 33k 2w. 5%	1-113960
R14	Resistor, 33k 2w.5%	1-113960
R15	Resistor, 33k 1/2w. 10%	1-113945
R16	Resistor, 10k 1/2w. 10%	1-111671
R17	Resistor, 8200 ohm 2w. 10%	1-113956
R18	Resistor, 1k 1/2w. 10%	1-111689
R19	Resistor, 7500 ohm 5w. 10%	1-113979
R20	Resistor, 6800 ohm 1/2w. 10%	1-113048
R21	Resistor, 10k 1/2w. 10%	1-111671
R22	Resistor, 1k 1/2w.10%	1-111689
R23	Resistor, 100 ohm 1/2w. 10%	1-111940
R24	Resistor, 18k 1/2w. 10%	1-113943
R25	Resistor, 33k 2w. 10%	1-113961
R26	Resistor, 100k 1/2w. 10%	1-113949
R27	Resistor, 10 Meg. 1/2w. 10%	1-111693

Circuit Reference	Description	Simpson Part Number
R28	Resistor, 2200 ohm 1/2w. 10%	1-113941
R29	Resistor, 2200 ohm 1/2w. 10%	1-113941
R30	Resistor, 12k 2w. 10%	1-113958
R31	Resistor, 100k 1/2w. 10%	1-113949
R32	Resistor, 150 ohm 1/2w. 5%	1-113927
R33	Potentiometer, 50k	1-113877
R34	Resistor, 91 ohm 1/2w. 10%	1-113923
R35	Resistor, 750 ohm 1/2w. 10%	1-111684
R36	Resistor, 91 ohm 1/2w. 10%	1-113923
R37	Resistor, 750 ohm 1/2w. 10%	1-111684
R38	Resistor, 91 ohm 1/2w. 10%	1-113923
R39	Resistor, 750 ohm 1/2w. 10%	1-111684
R40	Resistor, 91 ohm 1/2w. 10%	1-113923
R41	Resistor, 750 ohm 1/2w. 10%	1-111684
R42	Resistor, 82 ohm 1/2w. 10%	1-113922
R43	Resistor, 56k 1/2w. 10%	1-113947
R44, 45	Dual Potentiometer, 2k each section	1-113880
R46	Resistor, 75 ohm 1/2 w. 5%	1-114113
R47	Resistor, 750 ohm 1/2 w. 10%	1-111684
R48	Resistor, 91 ohm 1/2w. 10%	1-113923
R49	Resistor, 750 ohm 1/2w. 10%	1-111684
R50	Resistor, 91 ohm 1/2w. 10%	1-113923
R51	Resistor, 750 ohm 1/2w. 10%	1-111684
R52	Resistor, 91 ohm 1/2w. 10%	1-113923
R53	Resistor, 750 ohm 1/2w. 10%	1-111684
R54	Resistor, 82 ohm 1/2w. 10%	1-113922
R55	Potentiometer, 10 ohm	1-113881
R56	Resistor, 6.8 ohm 2w. 10%	1-113955
R57	Potentiometer, 50 ohm	1-113882
R58	Resistor, 7k 20w.	1-113919
R59	Potentiometer, 1 Meg. with switch	1-113870
R60	Potentiometer, 500k	1-114153
R61	Resistor, 2.7k 1/2w. 10%	1-113942
R62	Resistor, 330k 1/2w. 10%	1-113950
R63	Resistor, 150 ohm 1/2 w. 10%	1-113926
R64	Resistor, 47k 1/2w. 10%	1-113946
R65	Resistor, 220k 1w. 10%	1-113937
R66	Potentiometer, 250k	1-113875
R67	Resistor, 820k 1w. 10%	1-113938
R68	Resistor, 220k 1w. 10%	1-113937
R69	Resistor, 100k 1/2w. 10%	1-113949
R70	Resistor, 10 Meg 1/2w. 10%	1-111693
R71	Resistor, 10 Meg 1/2w. 10%	1-111693
R72	Resistor, 10 Meg. 1/2w. 10%	1-111693
R73	Resistor, 10 Meg 1/2w. 10%	1-111693
R74	Resistor, 68k 1w. 10%	1-113936
R75	Resistor, 68k 1w. 10%	1-113936
R76	Resistor, 68k 1w. 10%	1-113936
R77	Resistor, 68k 1w. 10%	1-113936
R78	Resistor, 2.7k 1w. 10%	1-113931
R79	Resistor, 10k 1/2w. 10%	1-113048
R80	Resistor, 33k 1w. 10%	1-113933
R81	Resistor, 27k 1/2w. 10%	1-113944
R82, 84	Potentiometer, 2 section, 1 Meg, 250k	1-113874

Circuit Reference	Description	Simpson Part Number
R83	Resistor, 68k 1w. 10%	1-113936
R85	Resistor, 27k 1/2w. 10%	1-113944
R86	Resistor, 220 ohm 1/2w. 10%	1-113928
R87	Resistor, 470 ohm 1/2w. 10%	1-113940
R88	Potentiometer, 500k	1-113871
R89	Resistor, 18k 1/2w. 10%	1-113943
R90	Potentiometer, 10k	1-113879
R91	Resistor, 6800 ohm 1/2w. 10%	1-113048
R92	Resistor, 56k 1/2w. 10%	1-113947
R93	Potentiometer, 10k	1-113879
R94	Resistor, 10k 1/2w. 10%	1-111671
R95	Resistor, 6800 ohm 1/2w. 10%	1-113048
R96	Potentiometer, 25k	1-113878
R97	Resistor, 39k 1w. 10%	1-113934
R98	Resistor, 39k 1w. 10%	1-113934
R99	Resistor, 56k 1/2w. 10%	1-113947
R100	Potentiometer, 10k	1-113879
R101	Resistor, 10k 1/2w. 10%	1-111671
R102	Resistor, 6800 ohm 1/2w. 10%	1-113048
R103	Potentiometer, 10k	1-113879
R104	Resistor, 18k 1/2w. 10%	1-113943
R105	Resistor, 6800 ohm 1/2w. 10%	1-113048
R106	Potentiometer, 25k	1-113878
R107	Resistor, 2700 ohm 1/2w. 10%	1-113942
R108	Resistor, 10 Meg. 1/2w. 10%	1-111693
R109	Resistor, 2700 ohm 1/2w. 10%	1-113942
R110	Resistor, 10 Meg. 1/2w. 10%	1-111693
R111	Potentiometer, 500k	1-113871
R112	Resistor, 1 Meg. 1/2w. 10%	1-113952
R113	Potentiometer, 500k	1-113871
R114	Resistor, 12 Meg. 1/2w. 10%	1-113953
R115	Resistor, 12 Meg. 1/2w. 10%	1-113953
R116	Resistor, 2200 ohm 1/2w. 10%	1-113941
R117	Resistor, 680 ohm 1W. 10%	1-113929
R118	Potentiometer, 100k	1-113876
S1	Switch, A.M. GENERATOR RANGE	1-113889
S2	Switch, POWER	1-113883
S3	Switch, SIGNAL	1-113884
S4	Switch, F. M. GENERATOR	1-113885
S5	Switch, F.M. ATTENUATOR	1-113886
S6	Switch, SIGNAL ATTENUATOR	1-113886
S7	Switch, FUNCTION	1-113888
S8	Switch, HORIZ. SENS.	1-113890
S9	Switch, VERTICAL SENS.	1-113890
S10	Switch, SWEEP RANGE	1-113887
T1	Transformer, Plate	10-890038
T2	Transformer, Modulation	10-890037
T3	Transformer, Filament	10-890036
V1	Tube, 6C4, A.M. Oscillator	1-113975
V2	Tube, 6J6, Crystal oscillator and mixer	1-113639
V3	Tube, 6C4, Audio oscillator	1-113975
V4	Tube, 6AK5, F. M. oscillator	1-113611
V5	Tube, 6C4, 140 mc. oscillator	1-113975
V6	Tube, 6AK5, F.M. mixer	1-113611

Circuit Reference	Description	Simpson Part Number
V7	Tube, 6C4, F. M. blanking	1-113975
V8	Tube, 5Y3GT, Generator rectifier (or 5Z4)	1-114671 (1-113976)
V9	Tube, 6X4, Oscilloscope negative rectifier	1-113974
V10	Tube, 6X4, Oscilloscope positive rectifier	1-113974
V11	Tube, 6J6, Linear sweep and blanking	3-310615
V12	Tube, 6J6, First vertical amplifier	3-310615
V13	Tube, 6J6, Second vertical amplifier	3-310615
V14	Tube, 6J6, First horizontal amplifier	3-310615
V15	Tube, 6J6, Second horizontal amplifier	3-310615
V16	Tube, 3KP1, Cathode ray tube	1-113977
Y1	Crystal diode, 1N34	1-113852
Y2	Crystal, 5.0 mc. .05%	1-113965
	Output cable with termination box	0-008370
	High frequency probe and cable	10-890080
	Oscilloscope cables	0-008371
	Dial assembly, A.M.	10-890027
	Dial assembly, F.M.	10-890026
	Knob, pointer type	3-260180
	Knob, tuning type	1-114050

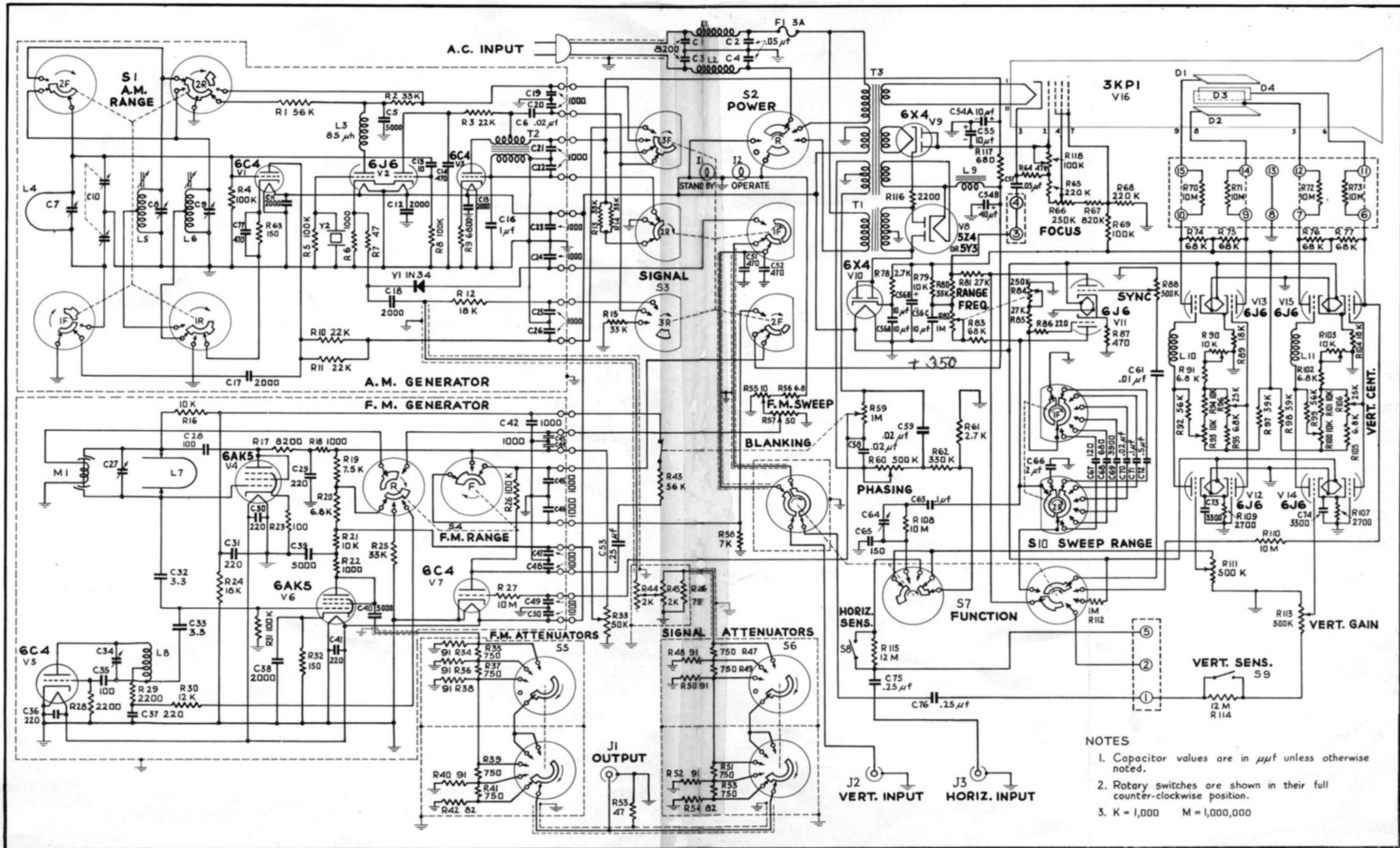

FIG. 40. SCHEMATIC DIAGRAM OF THE MODEL 480

